

PITTI

COOKING

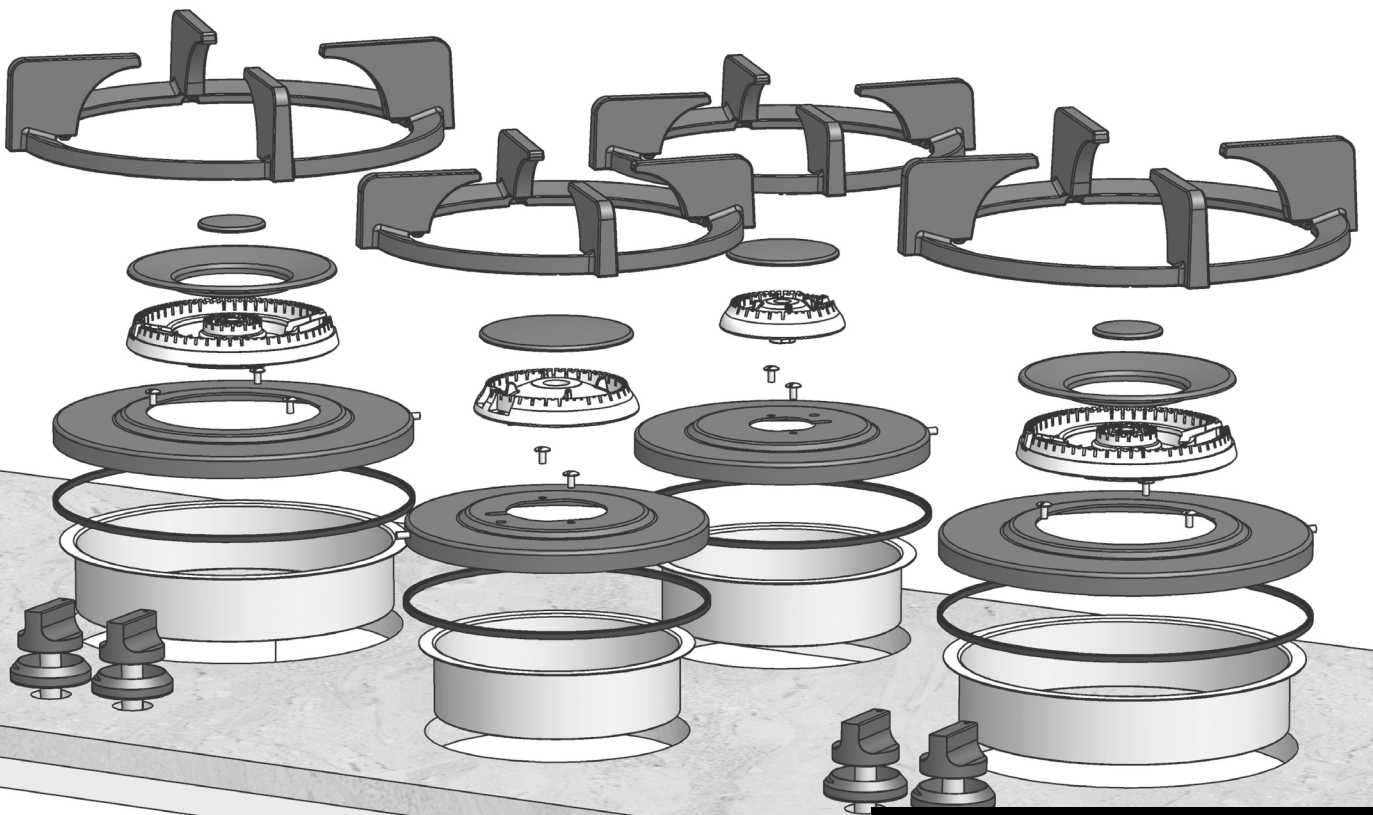

NL *Montagehandleiding*

EN *Installation instructions*

FR *Notice de montage*

DE *Montageanleitung*

ES *Instrucciones de instalación*

IT *Manuale per l'utente*

**Gas
Top Side**

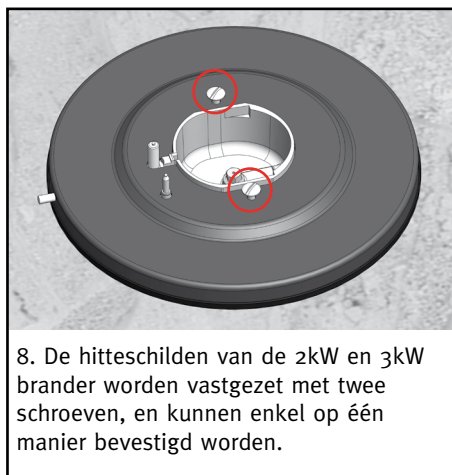
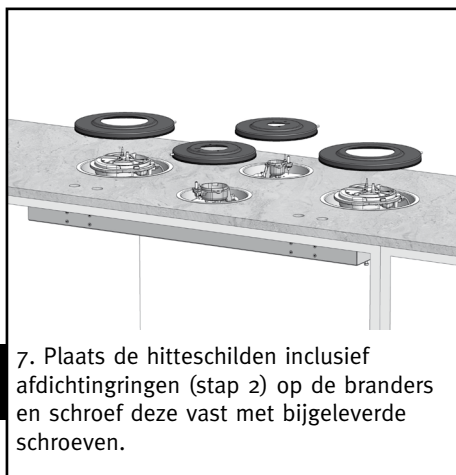
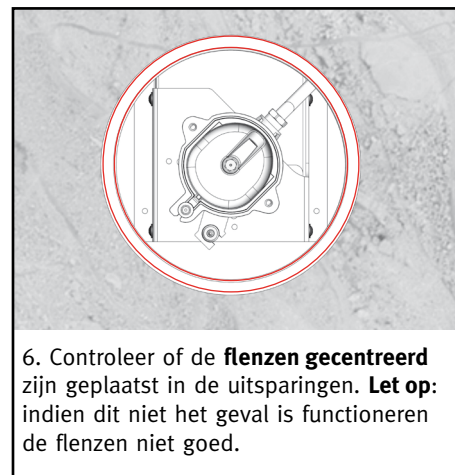
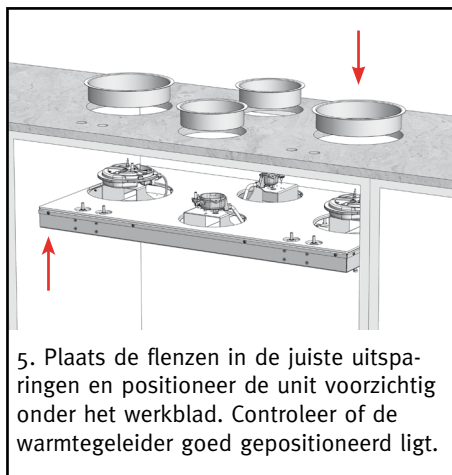
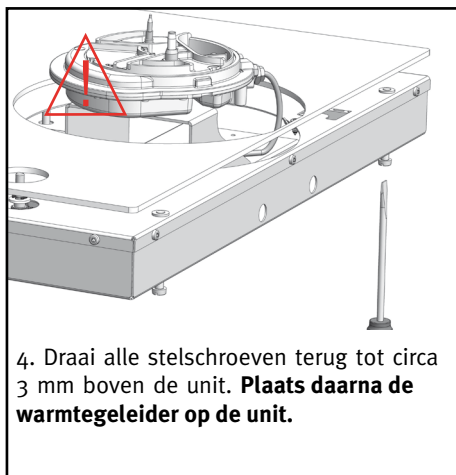
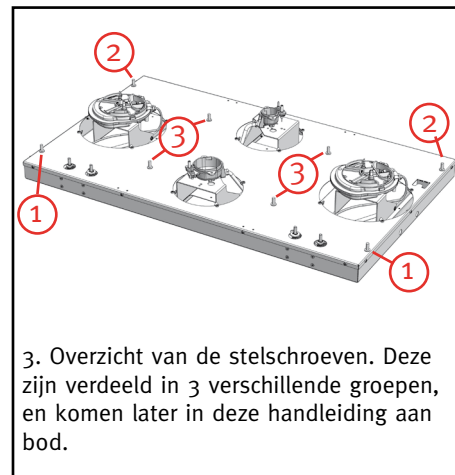

NL

Belangrijk!



Bij het **niet** juist afstellen van de bedieningsknoppen zullen de branders niet of slecht ontvlammen.

Om de **garantie** en het **goed functioneren van de kookunit** te waarborgen dient de montage, zoals beschreven in deze handleiding, zorgvuldig uitgevoerd te worden.



10. Let op: de **plakstrip** onder de afdichtingschaal van de knop mag nog **niet worden verwijderd**.



11. Schuif de unit voorzichtig in positie: zorg dat de **gaskranen gecentreerd** staan met de **uitsparingen** van het werkblad.



12. Druk de knoppen stevig op de gaskranen, met de markering naar voren gericht. Druk de knop in, en controleer of deze terugspringt in de rustpositie.



13. Bij het juist plaatsen van de knoppen is er een smalle opening zichtbaar tussen de knop en de bovenzijde van het afdichtingschaaltje.

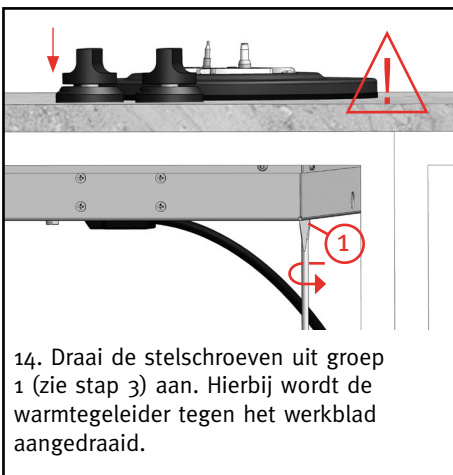

14. Draai de stelschroeven uit groep 1 (zie stap 3) aan. Hierbij wordt de warmtegeleider tegen het werkblad aangedraaid.

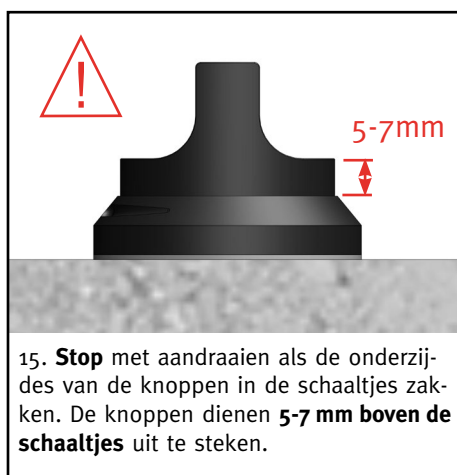

15. **Stop** met aandraaien als de onderzides van de knoppen in de schaaltes zakken. De knoppen dienen **5-7 mm boven de schaaltes** uit te steken.

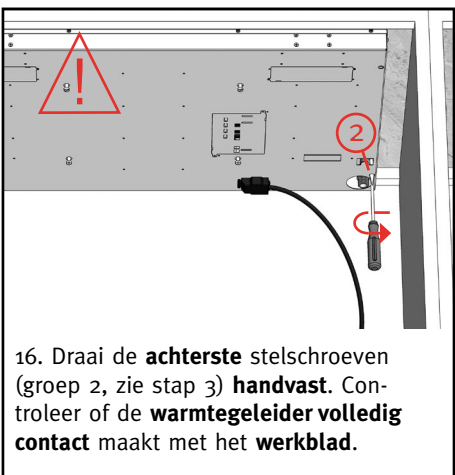

16. Draai de **achterste** stelschroeven (groep 2, zie stap 3) **handvast**. Controleer of de **warmtegeleider volledig contact** maakt met het **werkblad**.

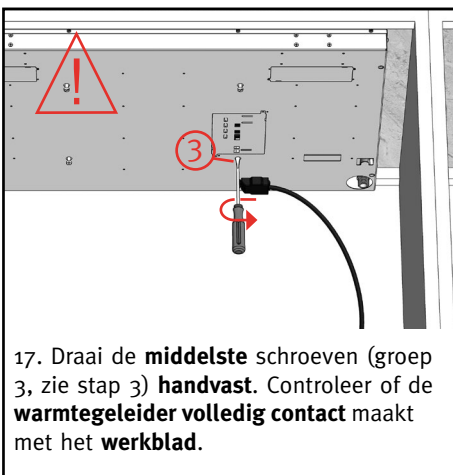

17. Draai de **middelste** schroeven (groep 3, zie stap 3) **handvast**. Controleer of de **warmtegeleider volledig contact** maakt met het **werkblad**.



18. Sluit de unit aan op gas en elektra en ontsteek de branders. Als de **vlammen doven** na ontsteking dienen de knoppen **opnieuw afgesteld te worden** (stap 14).



19. Verwijder de plakstrip onder het afdichtingschaaltje. Druk **knop en schaal** als **één geheel** op de gaskraan, zodat deze gecentreerd en uitgelijnd zijn.

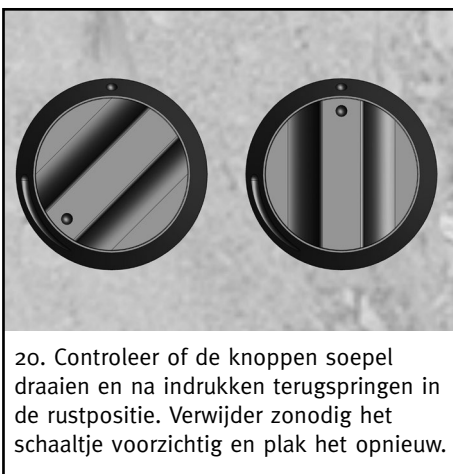

20. Controleer of de knoppen soepel draaien en na indrukken terugspringen in de rustpositie. Verwijder zonedig het schaaltes voorzichtig en plak het opnieuw.

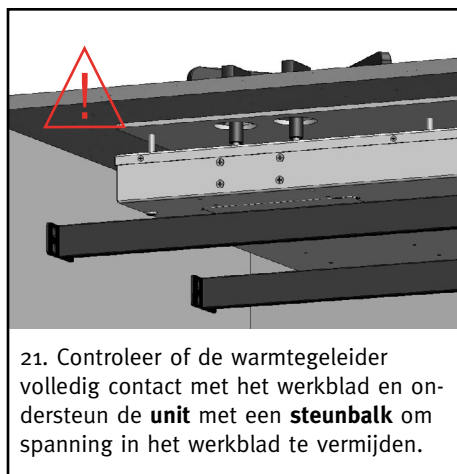

21. Controleer of de warmtegeleider volledig contact met het werkblad en ondersteun de **unit** met een **steunbalk** om spanning in het werkblad te vermijden.

Montagehandleiding ondersteuningsset

Inhoud van de verpakking:

2x ondersteuningsbalk



4x inzetstuk



16x kruiskopschroeven 4,2x16 mm



Benodigd gereedschap:

- Rolmaat
- Kruiskopschroevendraaier
- Metaalzaag



1. Bepaal de maatvoering van de kast en zaag de ondersteuningsbalken af. **LET OP! Juiste lengte balk = Afmeting binnenzijde kast – 4 mm.**

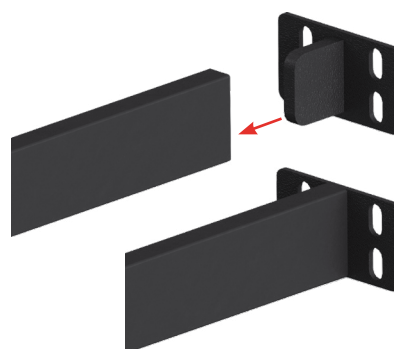

2. Plaats de inzetstukken in de uiteindes van de op maat gezaagde ondersteuningsbalken.

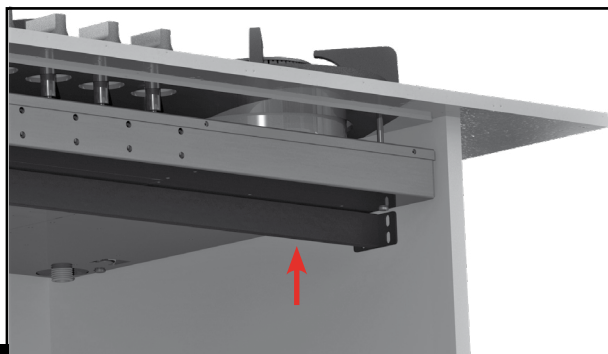

3. Plaats de ondersteuningsbalk tussen de kast, en positioneer deze tegen de onderzijde van de PITT Cooking unit. **LET OP DE POSITIONERING, ZIE STAP 4!**

* Minimale afstand van 80 mm

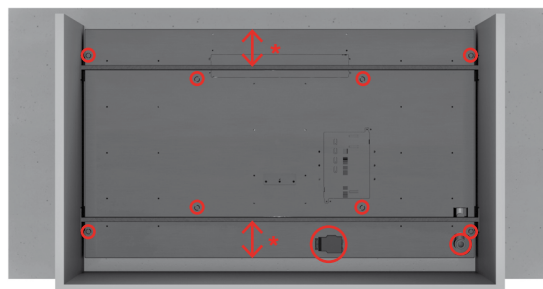

4. Positioneer de ondersteuningsbalk zo, dat de stelschroeven, gasaansluiting en het elektrablok vrij toegankelijk zijn.

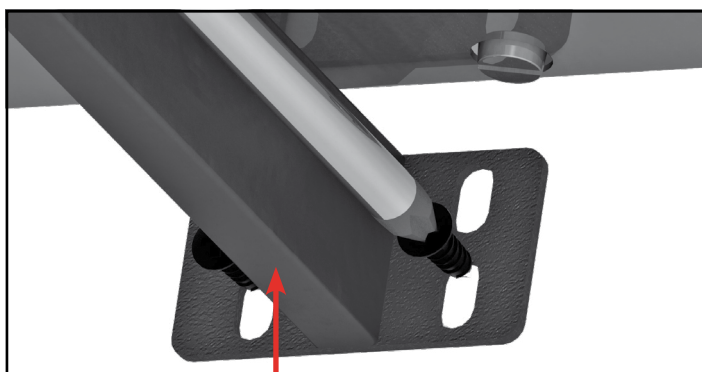

5. Duw de ondersteuningsbalk stevig tegen de onderzijde van de PITT Cooking unit en draai de onderste twee schroeven handvast. Herhaal deze stap voor de andere zijde van de kast.

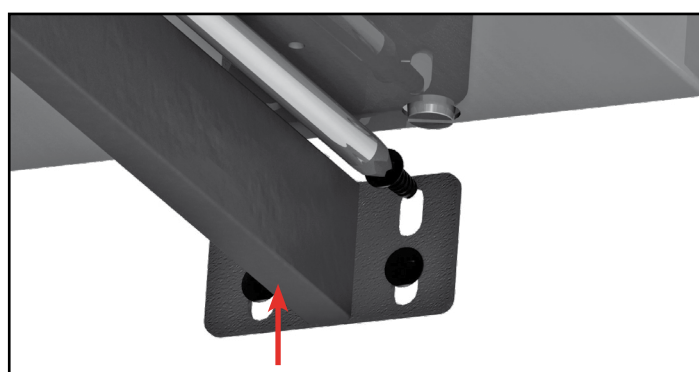

6. Duw de ondersteuningsbalk stevig tegen de onderzijde van de PITT Cooking unit en draai de bovenste twee schroeven volledig aan en vervolgens de onderste schroeven volledig aan.

PITT

COOKING

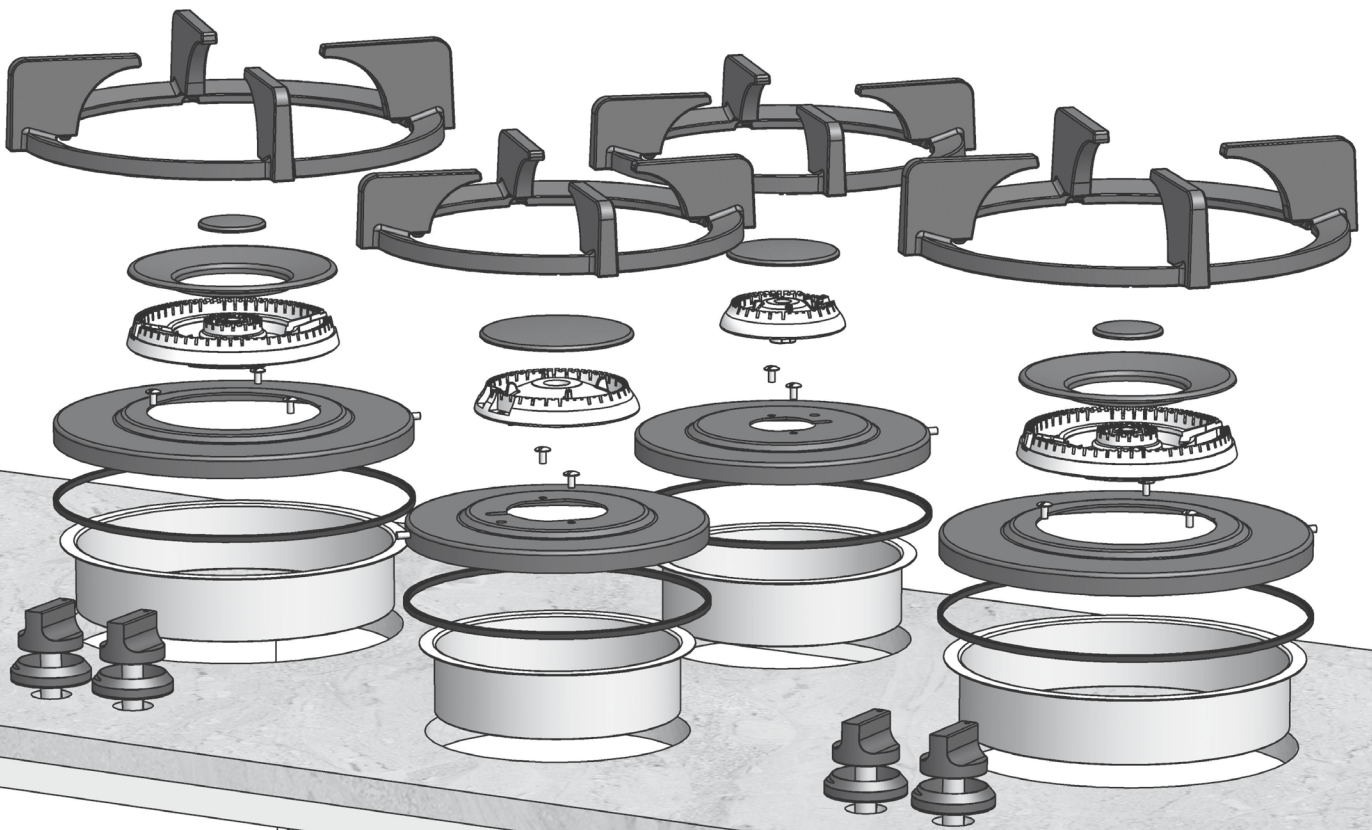

EN *Installation instructions*

**Gas
Top Side**

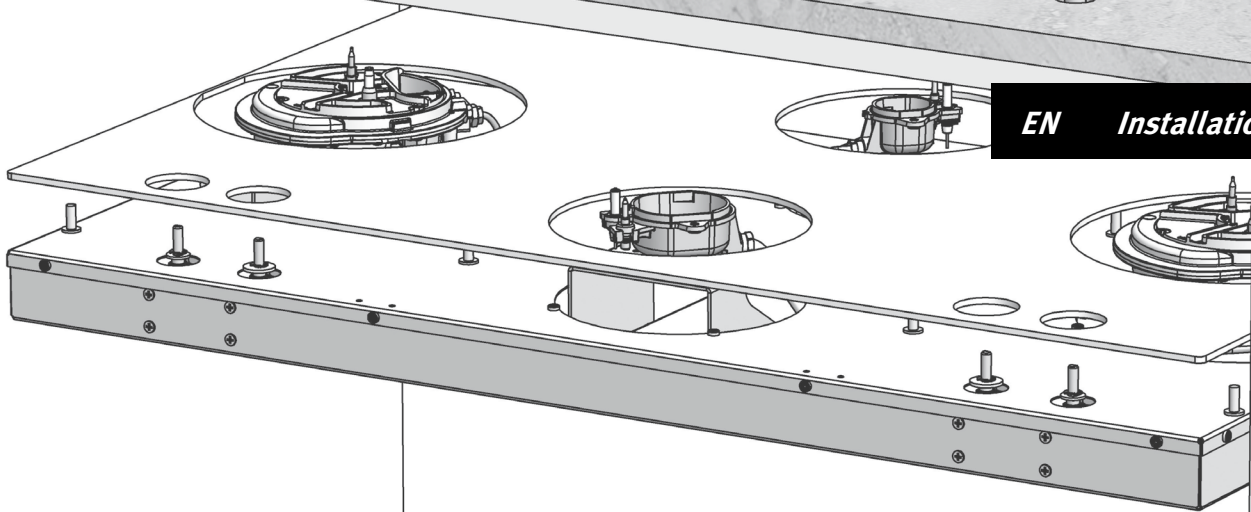

Installation instructions Top Side

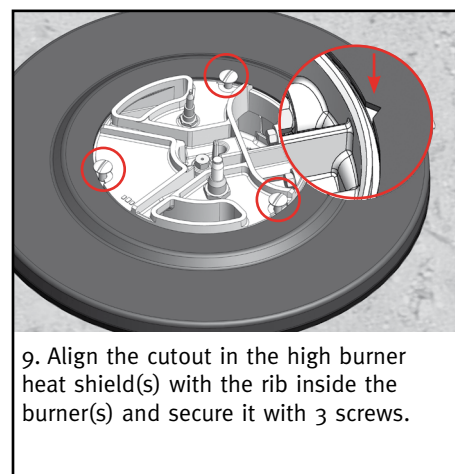
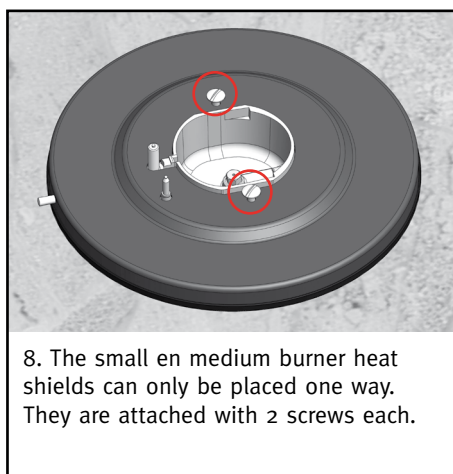
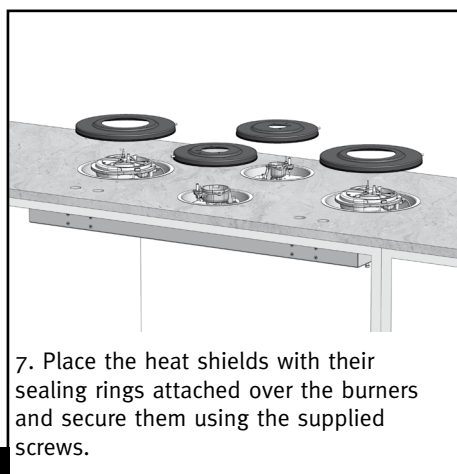
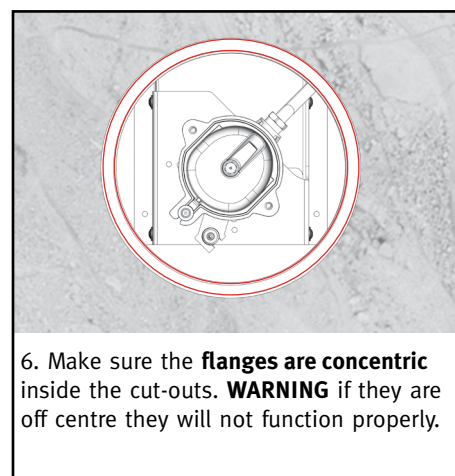
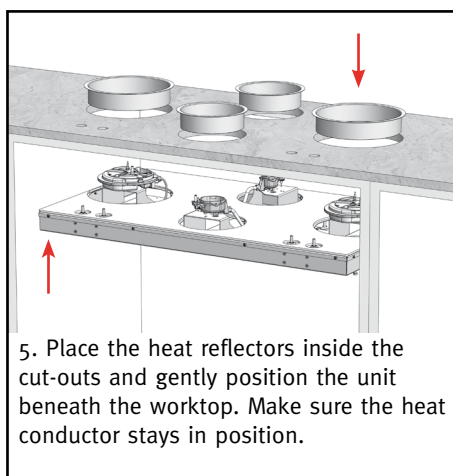
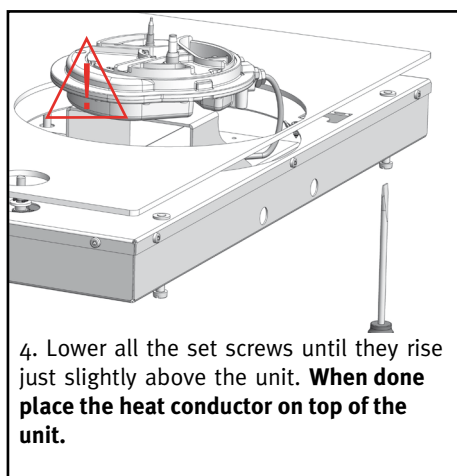
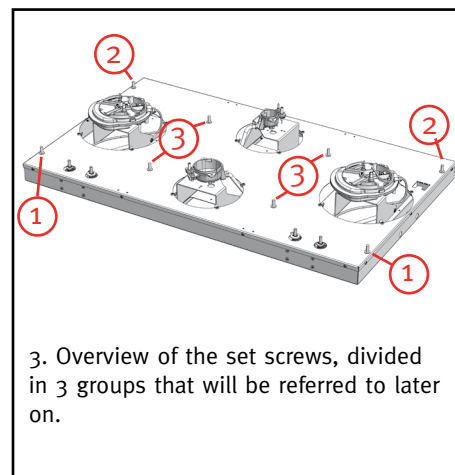
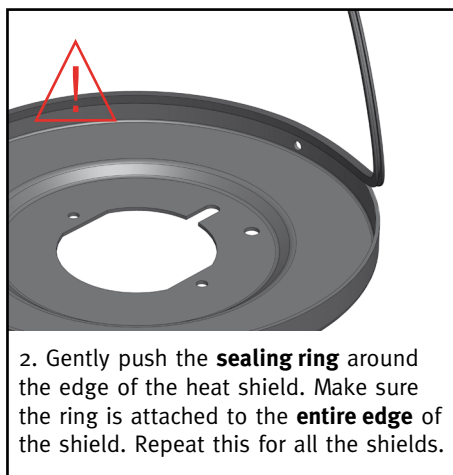
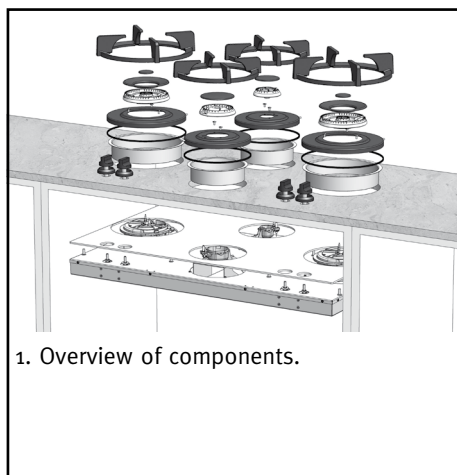

EN



Important!

When the control knobs are **not** properly adjusted the burners will not ignite or burn evenly.

For **warranty** and the **proper functioning** of the cooking unit ensure the mounting is as described in this manual to the letter.



10 Do **not separate** the **protective film** from the adhesive strip for the next steps!

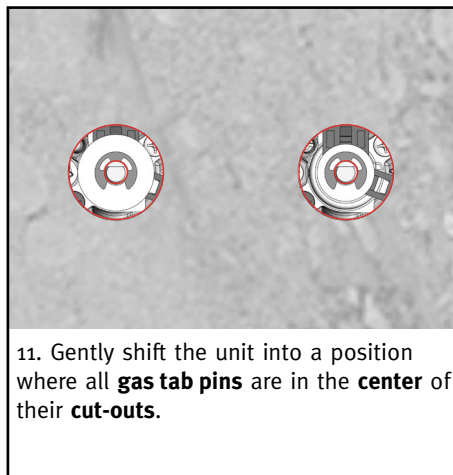

11. Gently shift the unit into a position where all **gas tab pins** are in the **center** of their **cut-outs**.

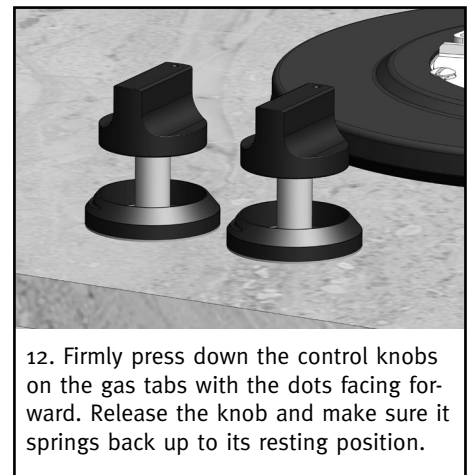

12. Firmly press down the control knobs on the gas tabs with the dots facing forward. Release the knob and make sure it springs back up to its resting position.

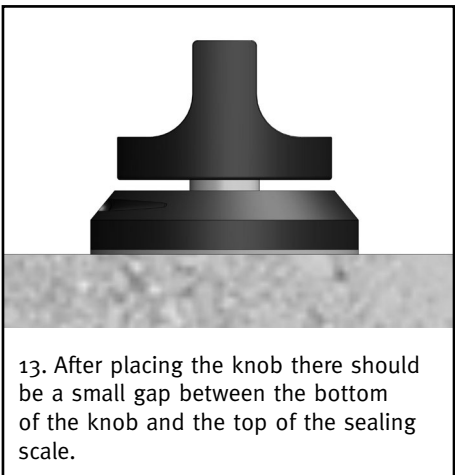

13. After placing the knob there should be a small gap between the bottom of the knob and the top of the sealing scale.

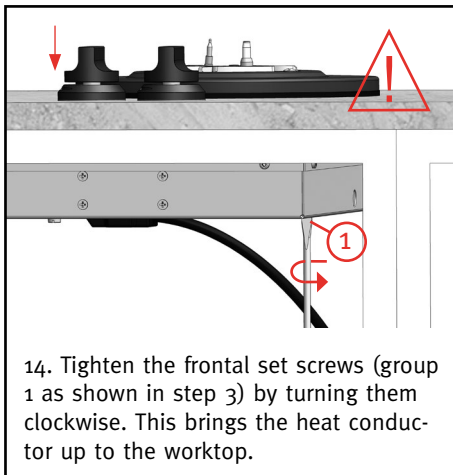

14. Tighten the frontal set screws (group 1 as shown in step 3) by turning them clockwise. This brings the heat conductor up to the worktop.

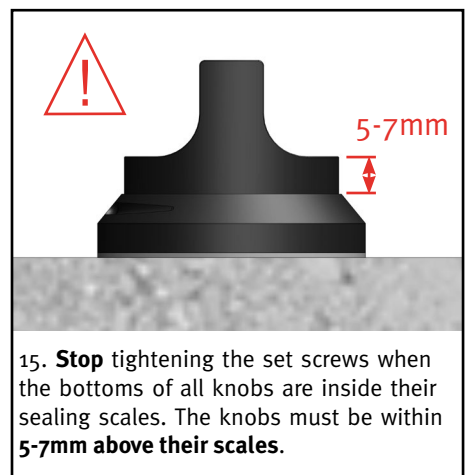

15. **Stop** tightening the set screws when the bottoms of all knobs are inside their sealing scales. The knobs must be within **5-7mm** above their scales.

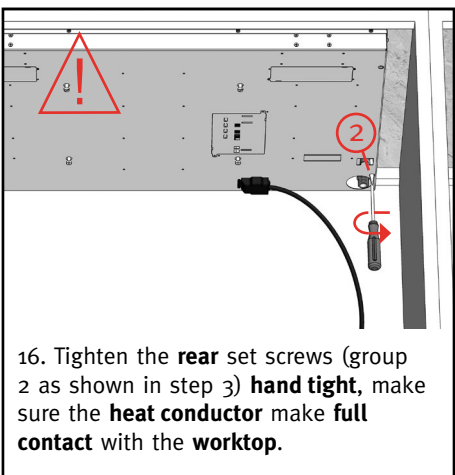

16. Tighten the **rear** set screws (group 2 as shown in step 3) **hand tight**, make sure the **heat conductor** make **full contact** with the **worktop**.

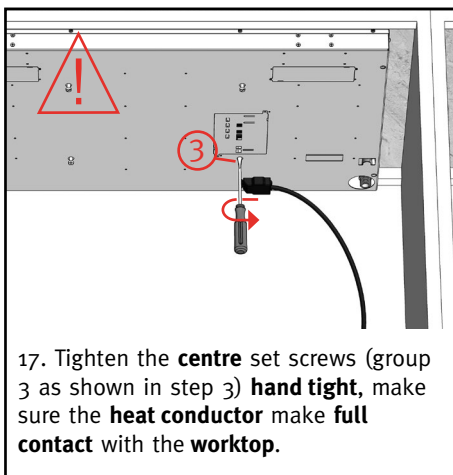

17. Tighten the **centre** set screws (group 3 as shown in step 3) **hand tight**, make sure the **heat conductor** make **full contact** with the **worktop**.

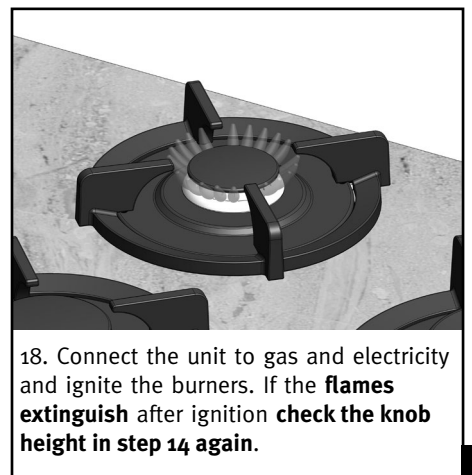

18. Connect the unit to gas and electricity and ignite the burners. If the **flames extinguish** after ignition **check the knob height in step 14** again.

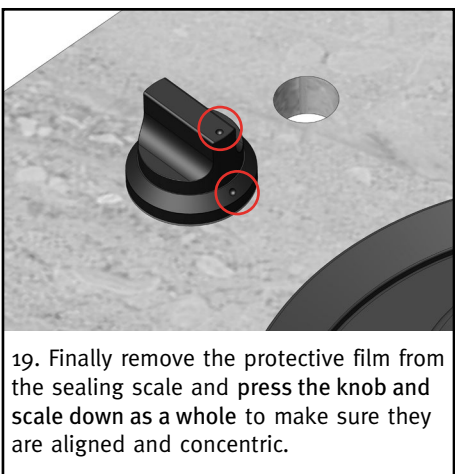

19. Finally remove the protective film from the sealing scale and press the knob and scale down as a whole to make sure they are aligned and concentric.

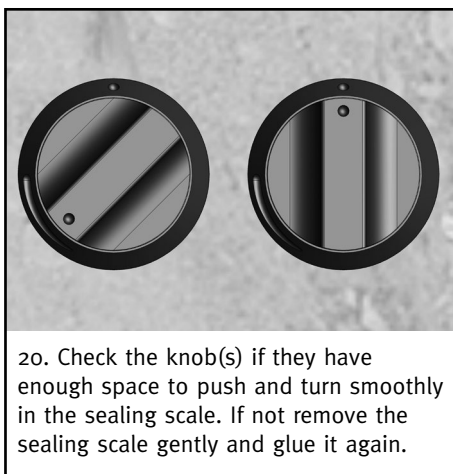

20. Check the knob(s) if they have enough space to push and turn smoothly in the sealing scale. If not remove the sealing scale gently and glue it again.

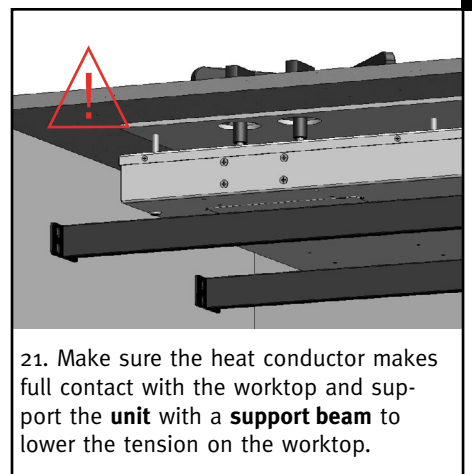

21. Make sure the heat conductor makes full contact with the worktop and support the **unit** with a **support beam** to lower the tension on the worktop.

Instructions for installation of support set

Contents of package:

2x support beams



4x inserts



16x cross-point screws 4,2x16 mm



Tools needed:

- Measuring tape
- Cross-point screwdriver
- Metallic saw



1. Determine the dimensions of the cabinet and cut the support beams with the saw. **ATTENTION!** Correct length of the beam = the dimension of cabinet on the inside - 4 mm.

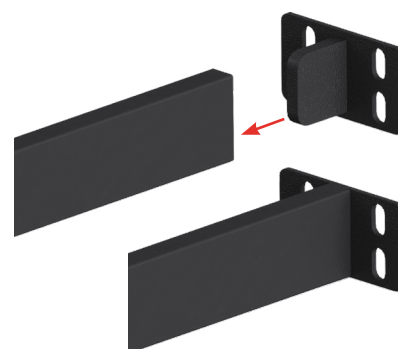

2. Place the inserts into the ends of the beams that have been cut to size.

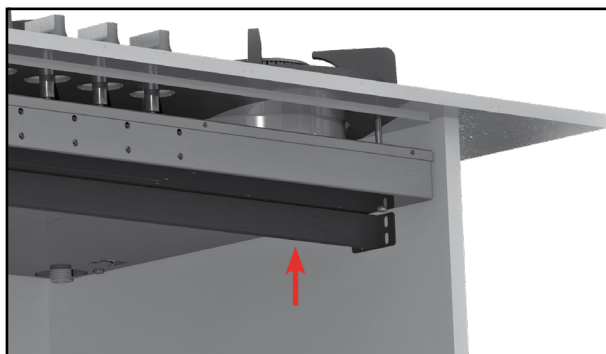

3. Place the beams between the cabinet and position it against the under side of the PITT Cooking unit. **ATTENTION: FOR THE POSITIONING, SEE STEP 4.**

* Minimum distance of 80 mm

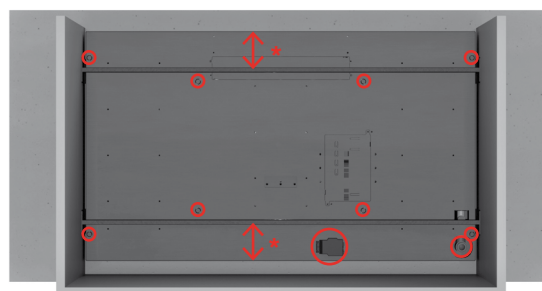

4. Position the beams in such a way that the screws, gas connection and the electricity block are freely accessible.

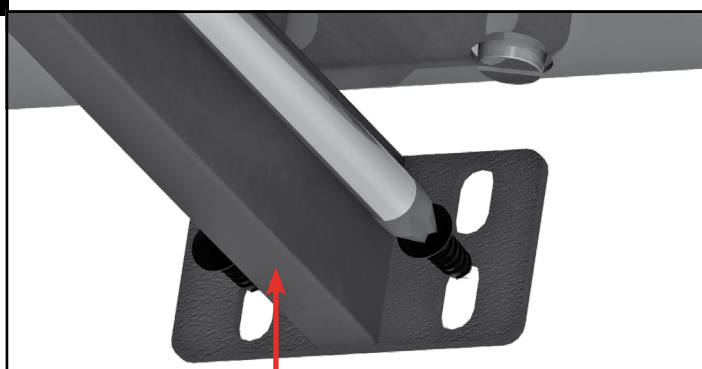

5. Push the beams firmly against the underside of the PITT Cooking unit and tighten the lower two screws by hand. Repeat this step for the other side of the cabinet.

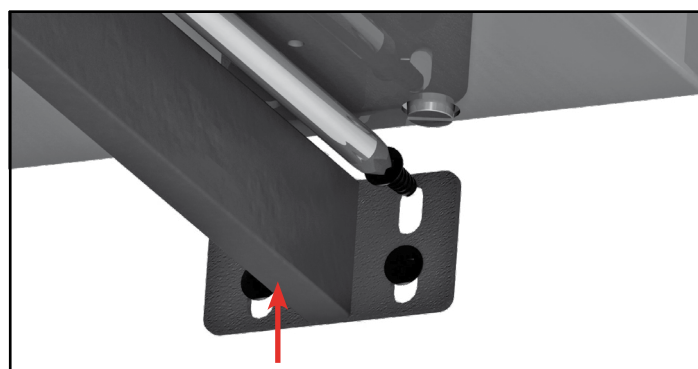

6. Push the beams firmly against the underside of the PITT Cooking unit and tighten the upper two screws completely. Then, tighten the lower screws completely.

PITT

COOKING

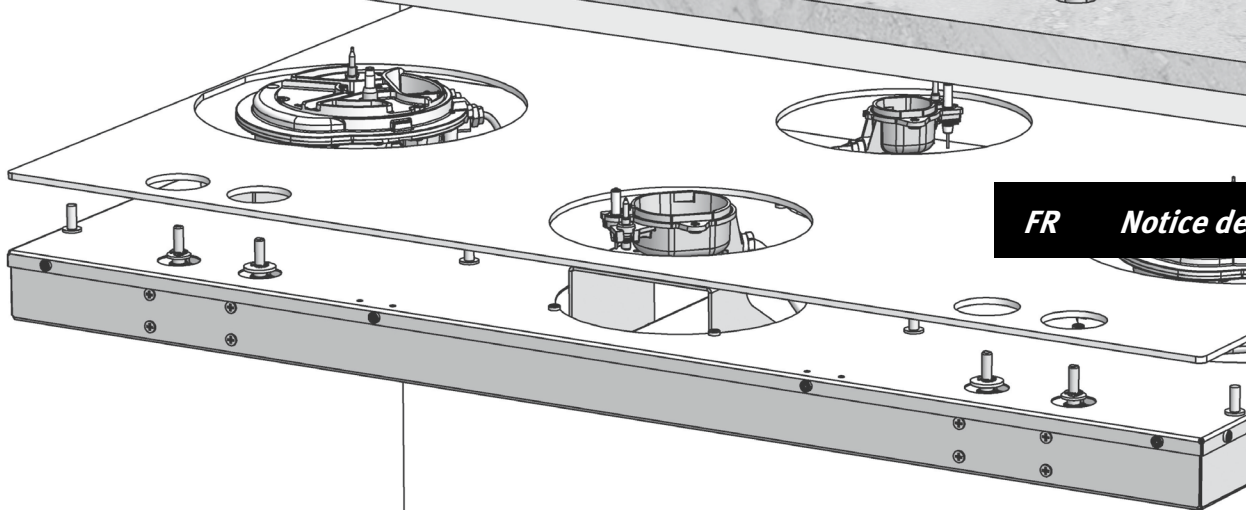
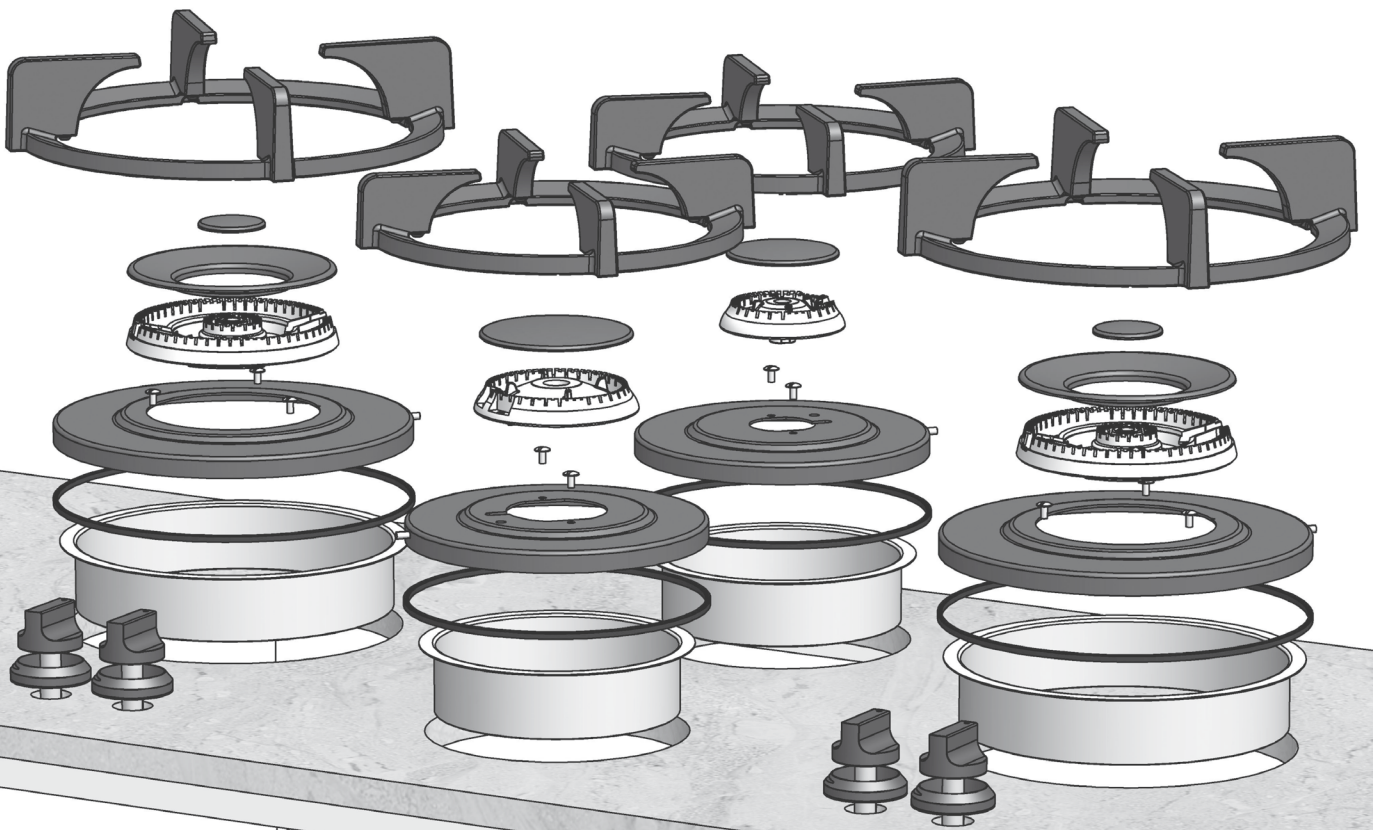

FR Notice de montage

Gas
Top Side

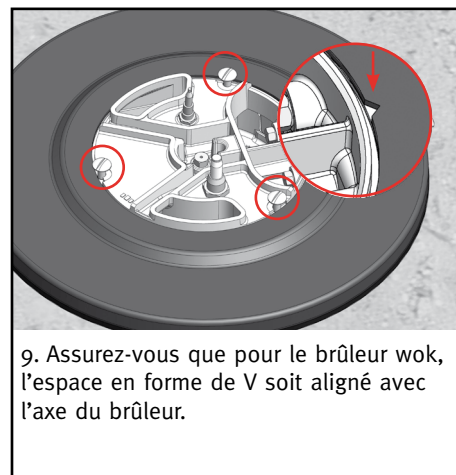
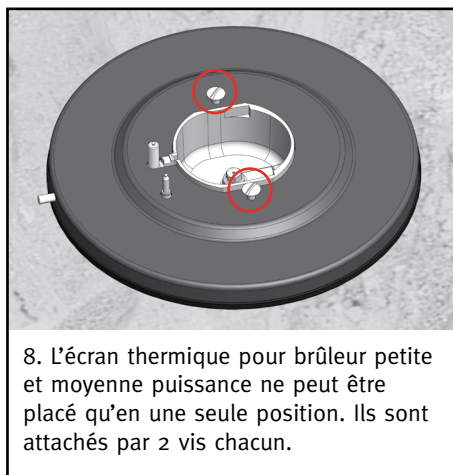
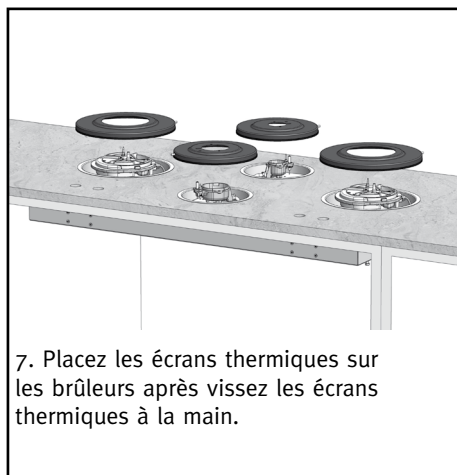
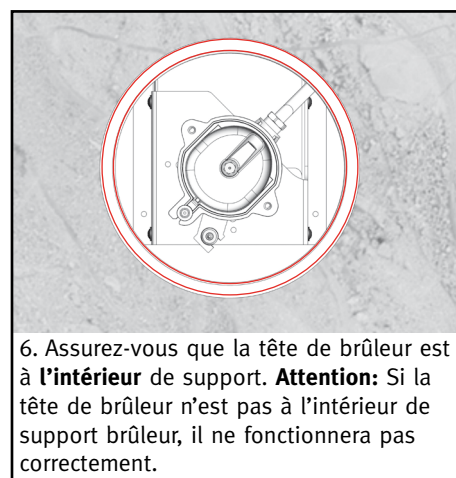
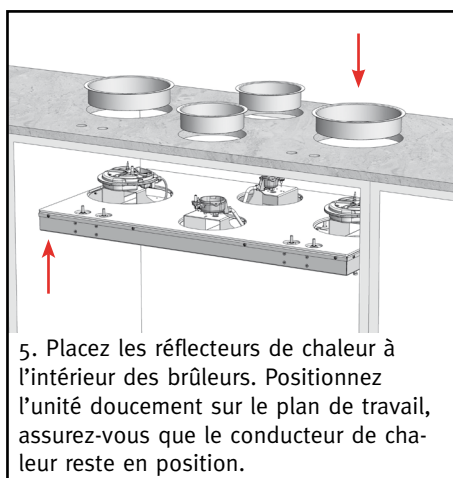
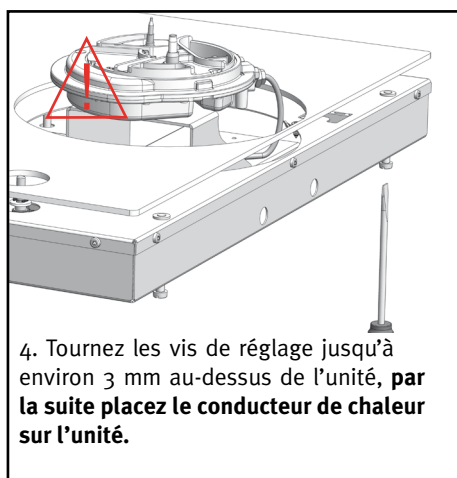
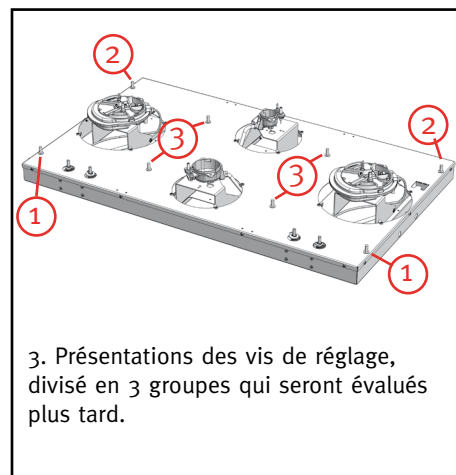
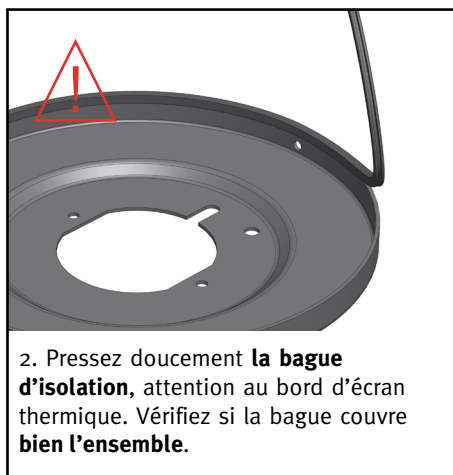
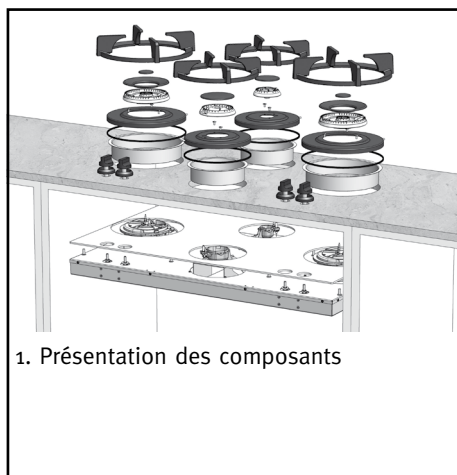

Attention!

En cas de mauvais réglage des boutons de commande les brûleurs ne s'allumeront pas ou pas bien.

Pour que la **garantie** et le **bon fonctionnement** de l'unité de cuisson soit assuré, il faut que le montage soit scrupuleusement effectué conformément aux descriptions.



10 Ne pas **enlever** la bande de protection pour les prochaines **étapes!**

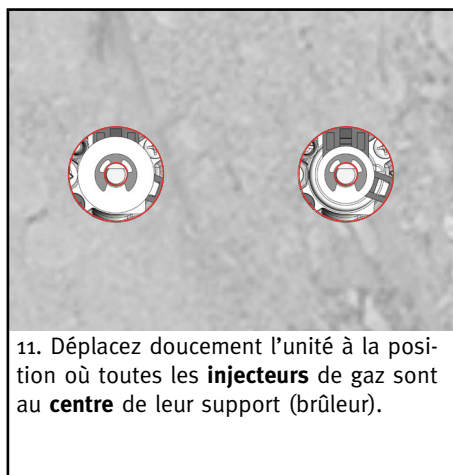

11. Déplacez doucement l'unité à la position où toutes les **injecteurs** de gaz sont au **centre** de leur support (brûleur).



12. Positionnez toutes les coques d'obturation avec les boutons de commande sur le plan de travail. Relâchez le bouton et assurez-vous qu'il revient à sa position normal de réglage.



13. Après avoir placé les boutons il devrait y avoir un petit écart entre le bouton et la coque d'obturation.

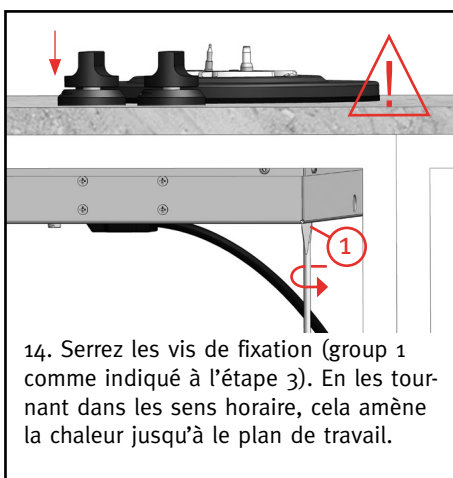

14. Serrez les vis de fixation (group 1 comme indiqué à l'étape 3). En les tournant dans les sens horaire, cela amène la chaleur jusqu'à le plan de travail.

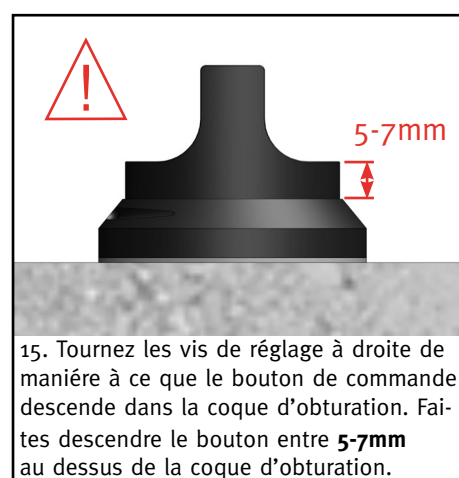

15. Tournez les vis de réglage à droite de manière à ce que le bouton de commande descende dans la coque d'obturation. Faites descendre le bouton entre **5-7mm** au dessus de la coque d'obturation.

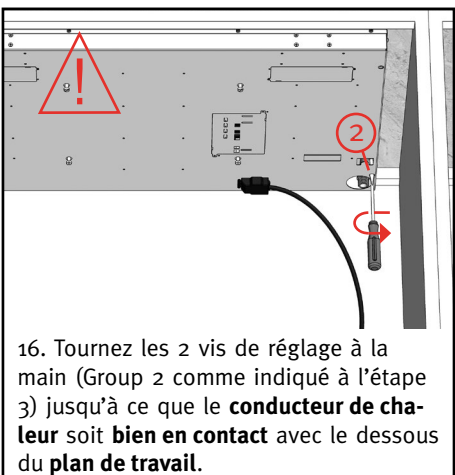

16. Tournez les 2 vis de réglage à la main (Group 2 comme indiqué à l'étape 3) jusqu'à ce que le **conducteur de chaleur** soit **bien en contact** avec le dessous du **plan de travail**.

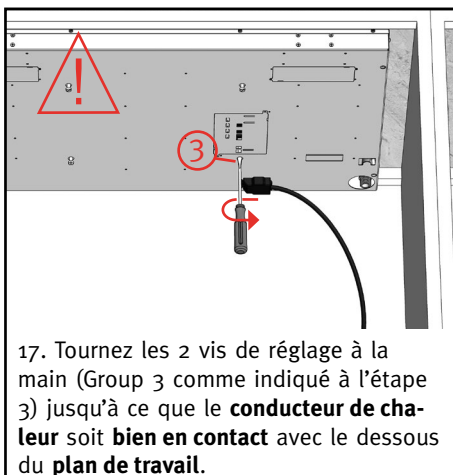

17. Tournez les 2 vis de réglage à la main (Group 3 comme indiqué à l'étape 3) jusqu'à ce que le **conducteur de chaleur** soit **bien en contact** avec le dessous du **plan de travail**.



18. Raccordez le tuyau de gaz. Reliez ensuite le cordon électrique. **Vérifiez** que chaque brûleur s'allume bien et reste allumé.

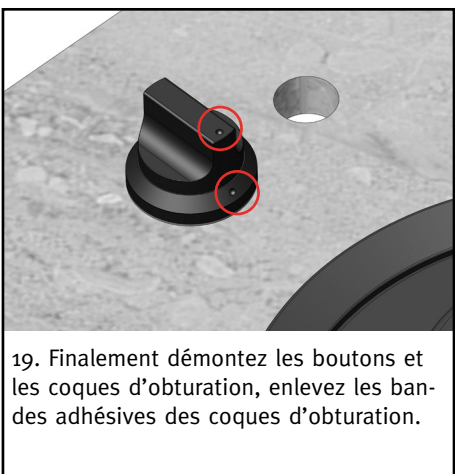

19. Finalement démontez les boutons et les coques d'obturation, enlevez les bandes adhésives des coques d'obturation.

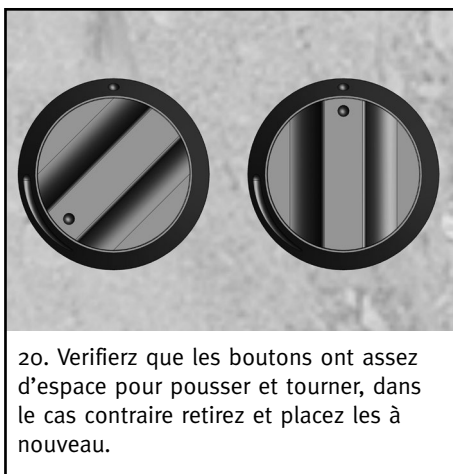

20. Vérifiez que les boutons ont assez d'espace pour pousser et tourner, dans le cas contraire retirez et placez les à nouveau.

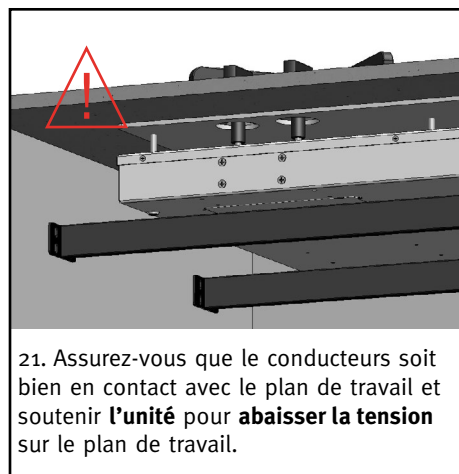

21. Assurez-vous que le conducteurs soit bien en contact avec le plan de travail et soutenir l'**unité** pour **abaisser la tension** sur le plan de travail.

Instruction de montage du support

Contenu de l'emballage:

2x lattes de soutien



4x pièces d'accroche



16x vis à tête cruciforme 4,2 x 16 mm



Outils requis :

- Mètre ruban
- Tournevis cruciforme
- Scie à métaux



1. Déterminez les dimensions de l'armoire et sciez les lattes de soutien. **NOTEZ BIEN ! La bonne longueur des lattes = Dimension de l'intérieur de l'armoire - 4mm.**

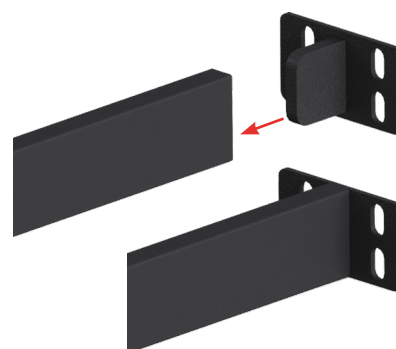

2. Placez les pièces d'accroche aux extrémités des lattes de soutien préalablement sciez à la bonne dimension.

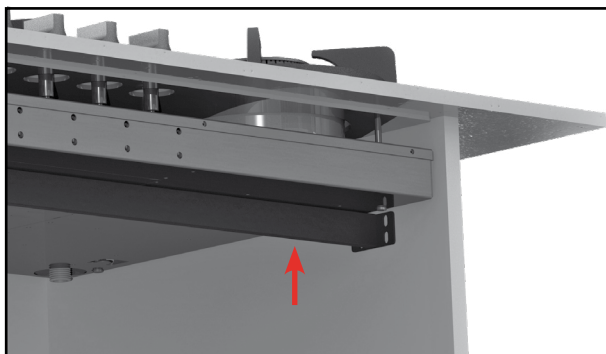

3. Placez la latte de soutien entre l'armoire et positionnez-la contre le dessous de l'appareil de cuisson PITT Cooking. **VÉRIFIEZ BIEN LE POSITIONNEMENT, REPORTEZ-VOUS À L'ÉTAPE 4 !**

* Distance minimale de 80 mm

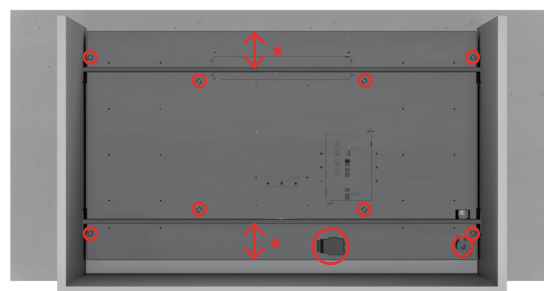

4. Mettez la barre de soutien de manière à ce que les vis de réglage, le branchement de la conduite de gaz et le bloc électrique soient facilement accessibles.

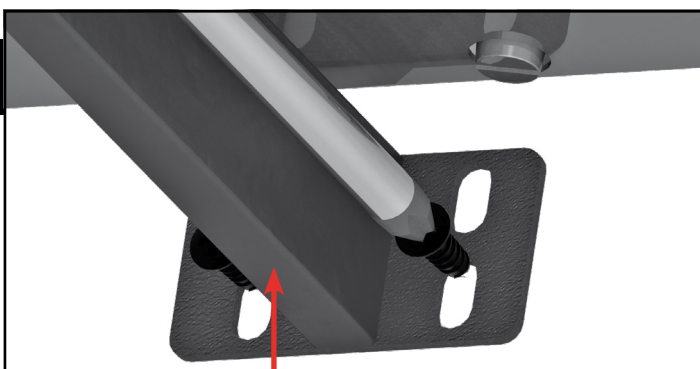

5. Poussez la latte de soutien fermement contre le dessous de l'appareil de cuisson et serrez légèrement les deux vis du bas. Répétez cette action pour l'autre côté de l'armoire.

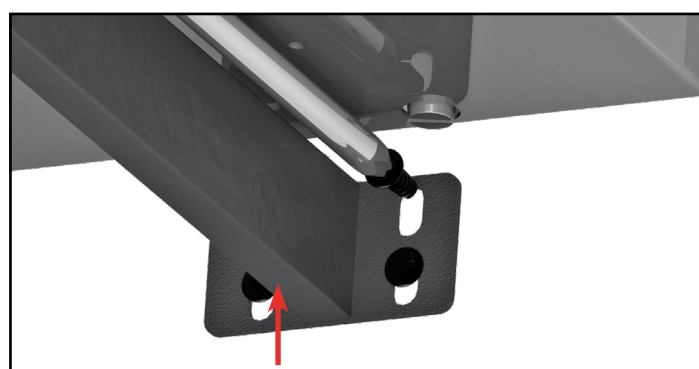

6. Poussez la latte de soutien fermement contre le dessous de l'appareil de cuisson PITT Cooking et serrez entièrement les deux vis du haut et ensuite serrez entièrement les vis du bas.

PITT
COOKING

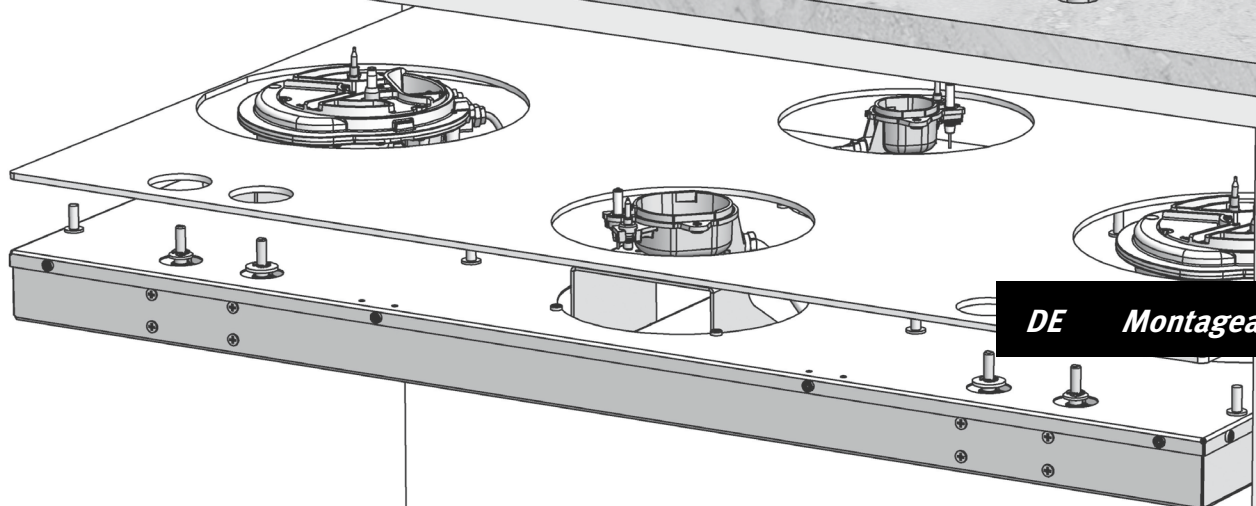
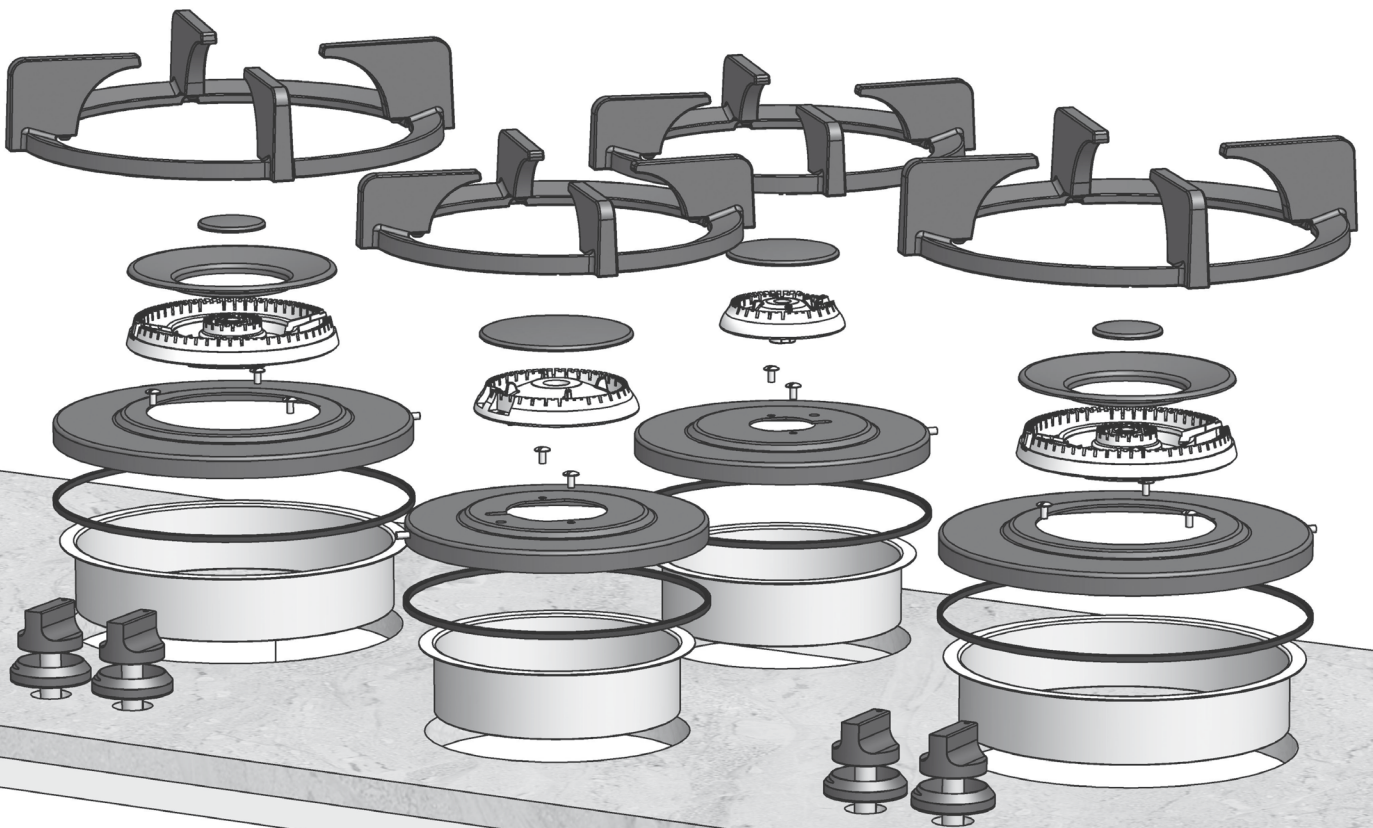

DE *Montageanleitung*

**Gas
Top Side**

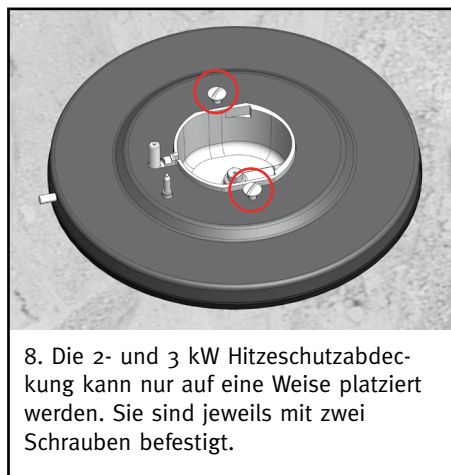
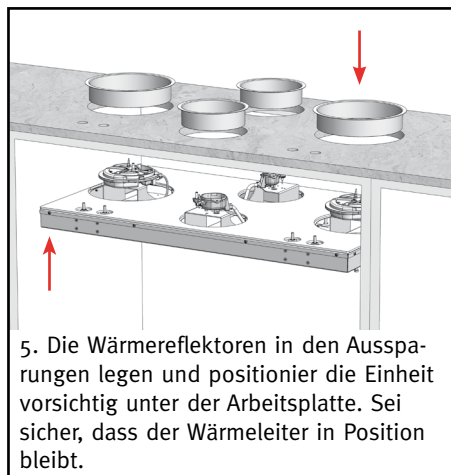
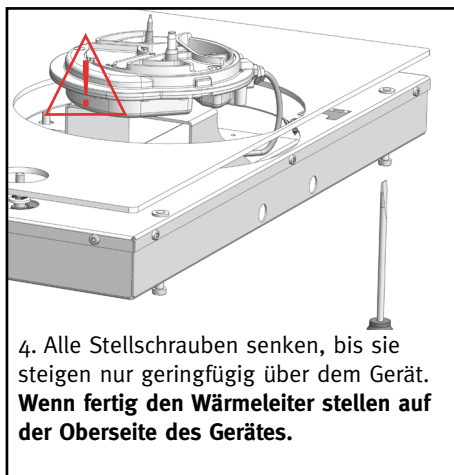
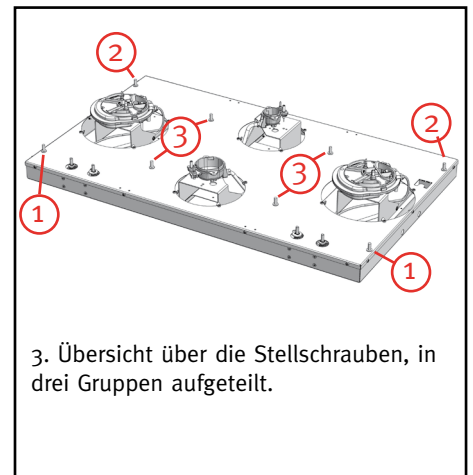
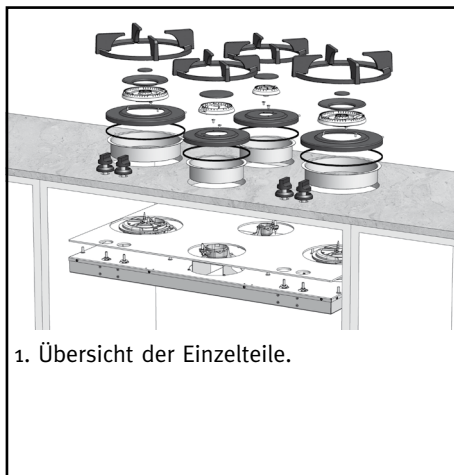

Wichtiger Hinweis!



Wenn die Regelknöpfe nicht korrekt eingestellt werden, lassen sich die Brenner nicht oder schlecht zünden.

Zur Gewährleistung der **Garantie** und des **einwandfreien Funktionierens der Kocheinheit** muss die Montage, wie in dieser Anleitung beschrieben, sorgfältig ausgeführt werden.

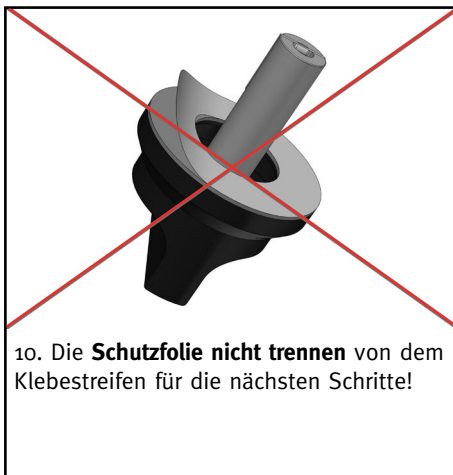

10. Die **Schutzfolie nicht trennen** von dem Klebestreifen für die nächsten Schritte!



11. Das Gerät in Position verschieben, in der alle **Gashahn Stifte** in der **Mitte** der **Ausschnitte** sind.



12. Die Bedienknöpfe auf den GasHahn Drucken mit den Punkten nach vorne. Sei sicher, das es wieder nach oben springt in seine Ruheposition.



13. Nach den Knopf platzieren sollte es eine kleine Lücke zwischen dem Boden des Knopfs und der Oberseite des Dichtmanschette sein.

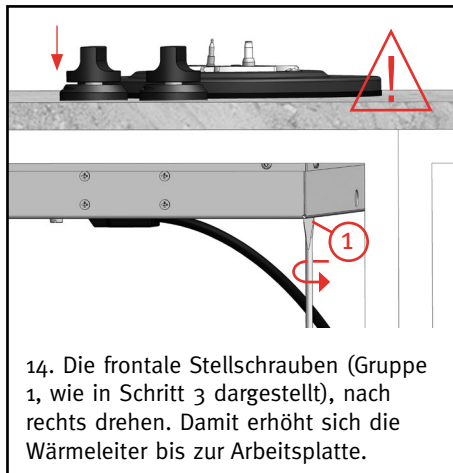

14. Die frontale Stellschrauben (Gruppe 1, wie in Schritt 3 dargestellt), nach rechts drehen. Damit erhöht sich die Wärmeleiter bis zur Arbeitsplatte.



15. **Stop** das Anziehen der Stellschrauben, wenn die Böden aller Noppen in ihren Dichtmanschette sind. Die Knöpfe müssen **über ihre Dichtmanschette in 5-7mm** sein.

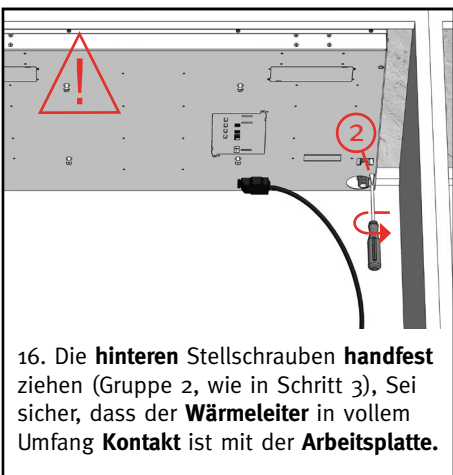

16. Die **hinteren** Stellschrauben **handfest** ziehen (Gruppe 2, wie in Schritt 3), Sei sicher, dass der **Wärmeleiter** in vollem Umfang **Kontakt** ist mit der **Arbeitsplatte**.

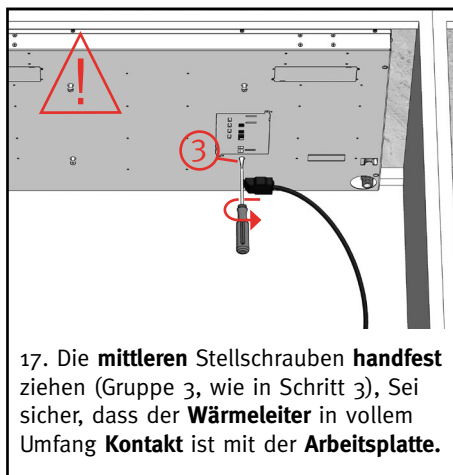

17. Die **mittleren** Stellschrauben **handfest** ziehen (Gruppe 3, wie in Schritt 3), Sei sicher, dass der **Wärmeleiter** in vollem Umfang **Kontakt** ist mit der **Arbeitsplatte**.



18. Schließ das Gerät an zu Gas und strom und zünd die Brenner. Wenn die **Flammen** nach der Zündung **löschen überprüf den Knopf Höhe in Schritt 14** wieder.



19. Entfernen die Schutzfolie von der Dichtmanschette und drück den Knopf und Dichtmanschette als Ganzes. Die punkten ausgerichtet und konzentrisch.



20. Überprüf den Knopf (n), wenn sie genügend Platz zu schieben und drehen haben. Wenn nicht die Dichtmanschette entfernen und wieder aufkleben.

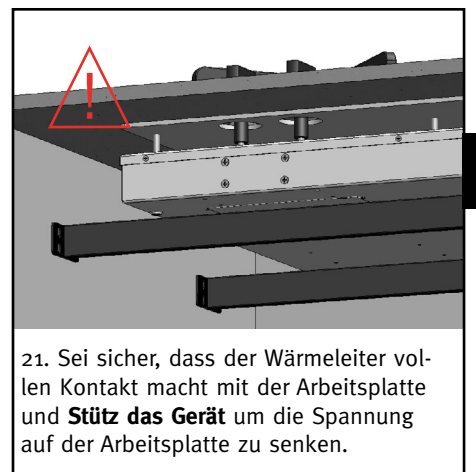

21. Sei sicher, dass der Wärmeleiter vol-len Kontakt macht mit der Arbeitsplatte und **Stütz das Gerät** um die Spannung auf der Arbeitsplatte zu senken.

Montageanleitung Stützbalken-Set

Verpackungsinhalt:



Benötigtes Werkzeug:

- Maßband
- Kreuzschlitzschraubenzieher
- Metallsäge



1. Bestimmen Sie die Abmessungen des Schrankes und sägen Sie die Stützbalken ab. **ACHTUNG! Richtige Balkenlänge = Maß Schrankinnenseite - 4 mm.**

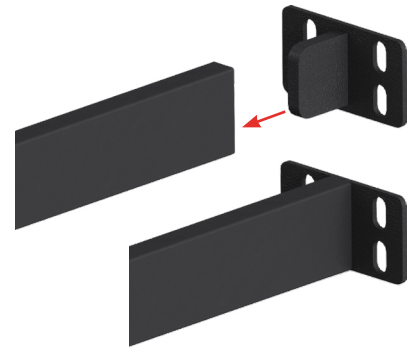

2. Platzieren Sie die Einsatzstücke in die Enden der auf Maß gesägten Stützbalken.

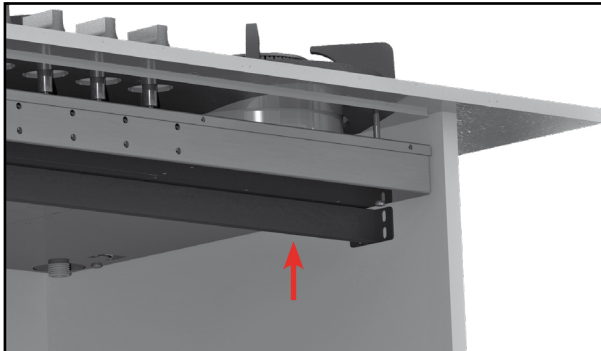

3. Setzen Sie den Stützbalken in den Schrank ein, und positionieren Sie ihn an der Unterseite der PITT Cooking Kocheinheit. **ACHTEN SIE AUF DIE POSITIONIERUNG, SIEHE SCHRITT 4!**

* Mindestabstand von 80 mm



4. Positionieren Sie den Stützbalken so, dass die Stellschrauben, sowie der Gas- und Stromanschluss frei zugänglich sind.

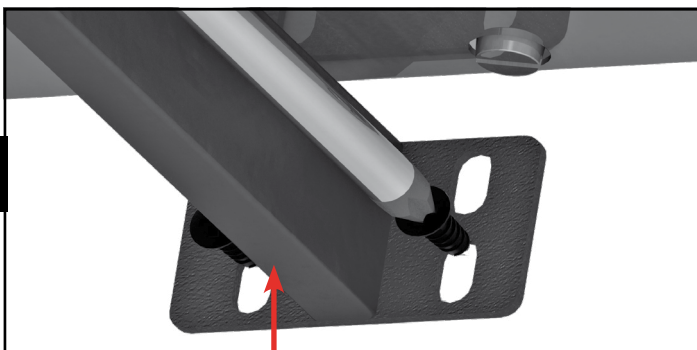

5. Drücken Sie den Stützbalken fest gegen die Unterseite der PITT Cooking Kocheinheit und ziehen Sie die untersten beiden Schrauben handfest an. Wiederholen Sie diesen Schritt auf der anderen Seite des Schrankes.

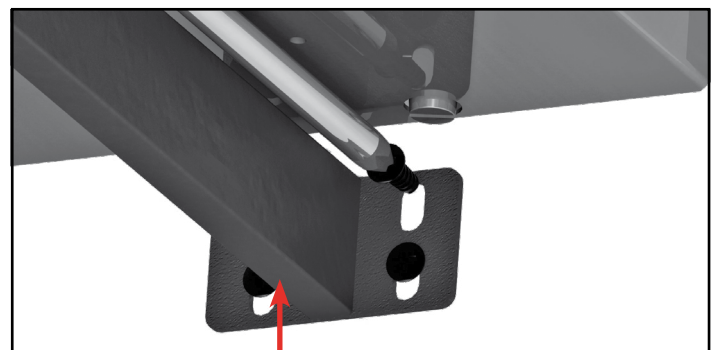

6. Drücken Sie den Stützbalken fest gegen die Unterseite der PITT Cooking Kocheinheit und ziehen Sie erst die oberen beiden Schrauben komplett an und anschließend auch die unteren Schrauben.

PITT

COOKING

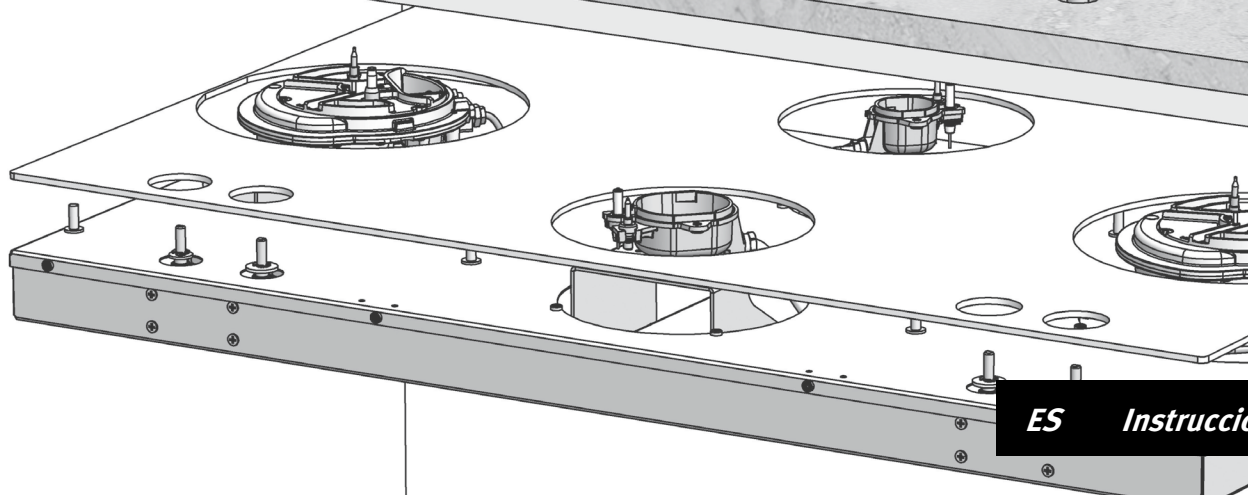
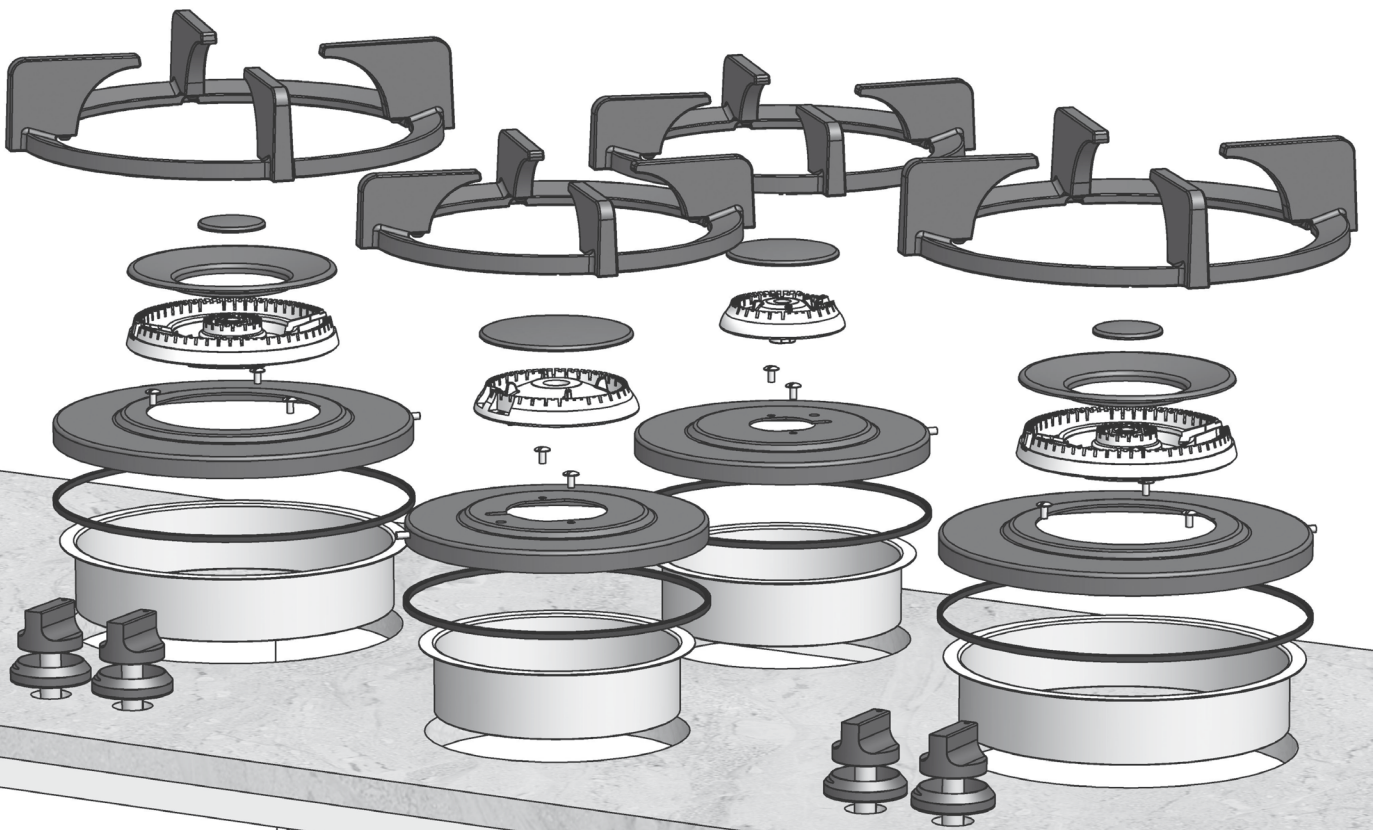

ES *Instrucciones de instalación*

Gas
Top Side

Instrucciones de instalación Top Side

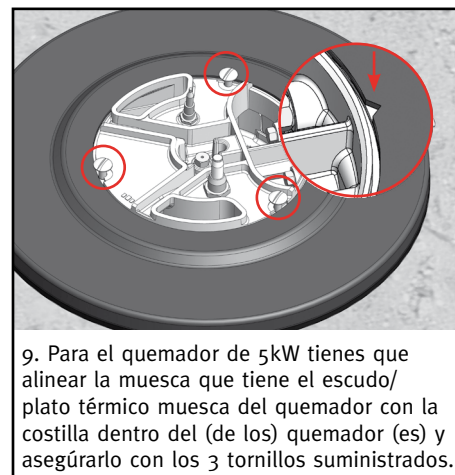
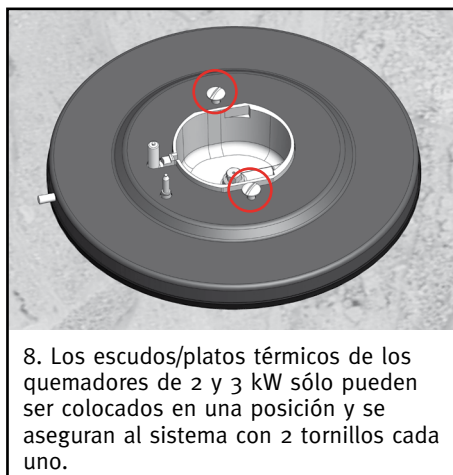
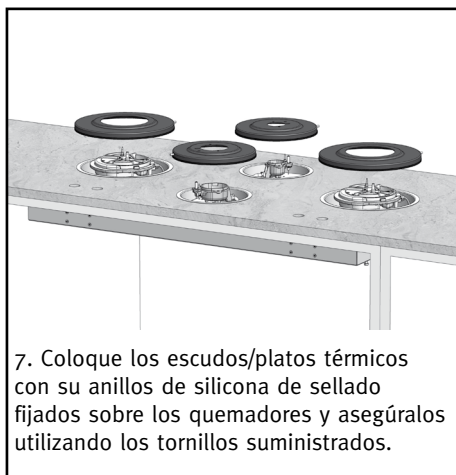
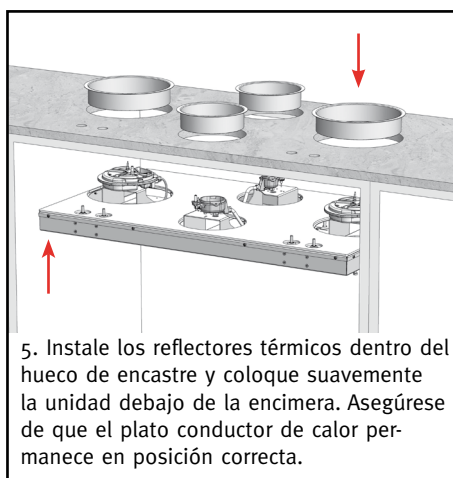
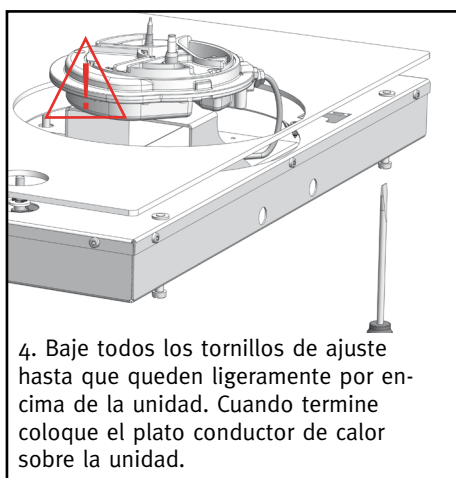
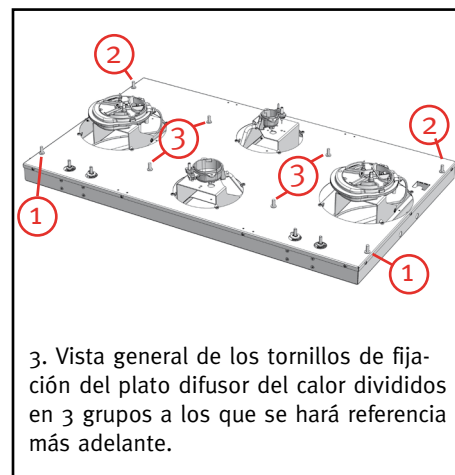
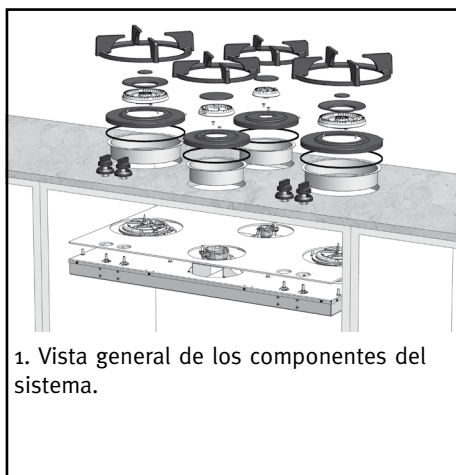

¡Importante!

Cuando los mandos no estén correctamente ajustados, los fuegos no se encenderán ni quemarán uniformemente.

Para la garantía y un buen correcto funcionamiento del sistema de cocción, asegúrate de seguir *exactamente* todas las etapas descritas en este manual de instalación.



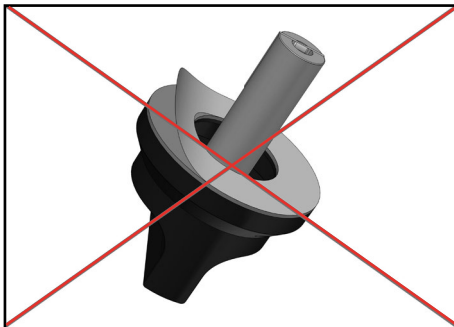

10. No despegar la película protectora de la tira adhesiva del aro del mando que apoyará en la encimera, antes de continuar con los siguientes pasos!

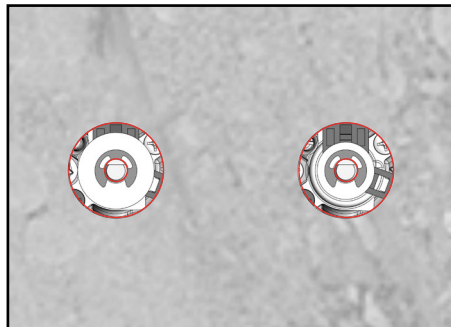

11. Deslice suavemente y sitúe la unidad en una posición donde todos los quemadores de gas estén en el centro de los huecos de encastre.

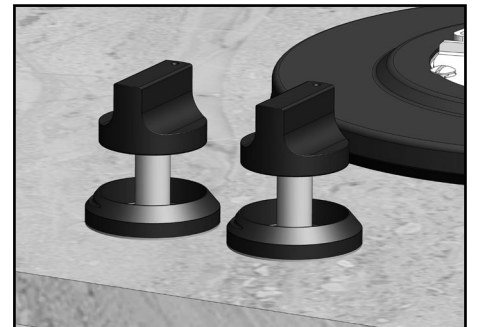

12. Presione firmemente hacia abajo los mandos sobre su anclaje a la placa con los puntos marcados hacia adelante. Suelte el mando y asegúrese de vuelve a su posición de reposo.

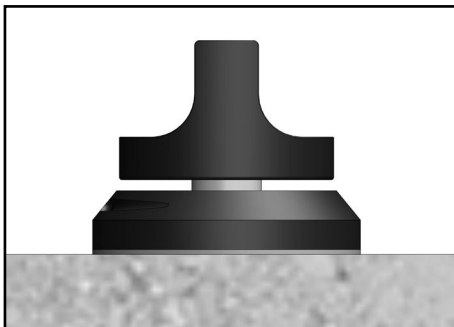

13. Después de colocar el mando, debe quedar un pequeño espacio entre la parte baja del mando y la parte alta del aro que se fijará posteriormente a la encimera.

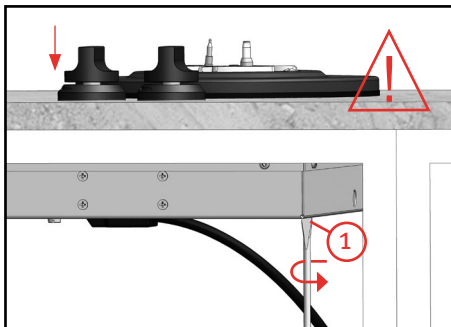

14. Apriete a mano los tornillos de fijación frontales (grupo 1 como se muestra en el paso 3) girándolos en el sentido de las agujas del reloj. Esto lleva el plato conductor de calor a la parte inferior de la encimera.

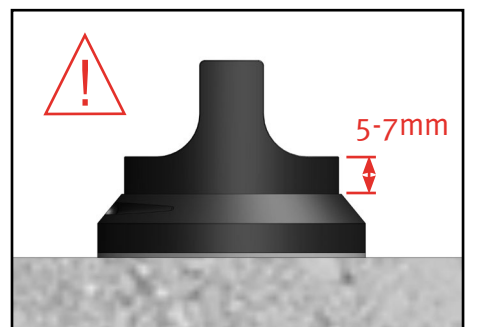

15. Deje de apretar de los tornillos cuando la parte baja de todos los mandos este dentro de los aros que están en contacto con la encimera. Los mandos deberán estar entre 5-7 mm por encima de los aros.

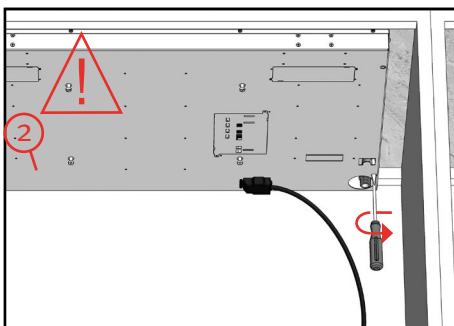

16. Apriete a mano los tornillos de ajuste traseros (grupo 2 como se muestra en el paso 3) y asegúrese de que el plato conductor de calor esté en pleno contacto con la parte inferior de la encimera.

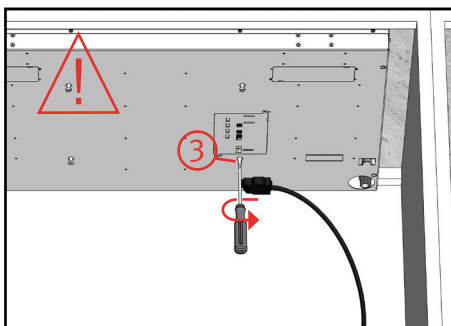

17. Apriete a mano los tornillos centrales (grupo 3 como se muestra en el paso 3) y asegúrate que el 17. Apriete los tornillos centrales (grupo 3 como se muestra en el paso 3) apretado a mano, y asegúrese de que el plato conductor de calor este en pleno contacto con la parte inferior de la encimera.

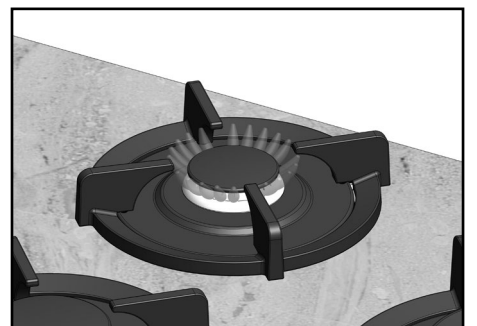

18. Conecte la unidad a la instalación de gas y electricidad y enciende todos los fuegos. Si las llamas se apagan después del encendido, comprobar de nuevo la altura de los mandos (paso 14).



19. Finalmente, retira la película protectora de la tira adhesiva del aro del mando, asegúrate que el aro y el mando estén perfectamente alineados y concéntricos al hueco de encastre y presiona a la vez mano y aro asegurándote que se pega a la encimera correctamente.

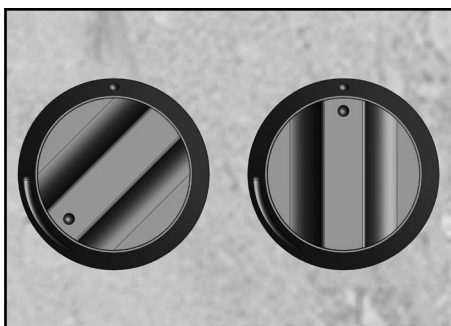

20. Compruebe si todas los mandos tienen suficiente espacio para empujar y girar suavemente sobre el aro sellado a la encimera. de no ser así, con cuidado despegas el aro de la encimera y pégalo de nuevo a la encimera en su posición correcta.

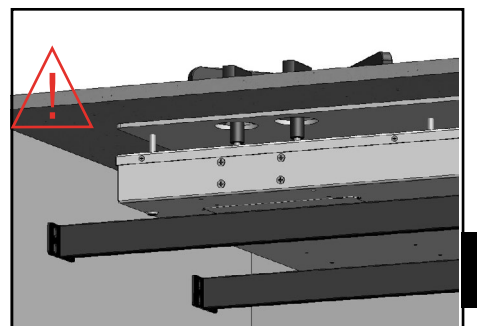

21. Asegúrese de que el plato conductor térmico esté en pleno contacto con la parte inferior de la encimera. Calza la unidad con las dos barras de soporte suministradas, para que soporte el peso de la unidad y descargue la tensión en la encimera.

Contenido del paquete:

2 barras de soporte



4 complementos



16 tornillos de estrella 4,2x16 mm



Herramientas necesarias:

- Cinta métrica extensible
- Destornillador de estrella
- Sierra para metales



1. Determine las dimensiones del armario y corte las barras de soporte. **ATENCIÓN: Longitud correcta de la barra = Dimensiones del interior del armario - 4 mm.**

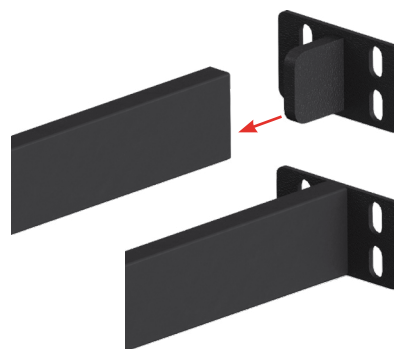

2. Coloque las piezas complementarias en los extremos de las barras de soporte cortadas a medida.

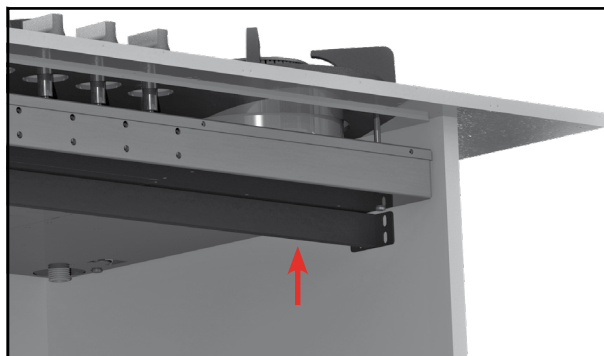

3. Ponga la barra de soporte en medio del armario y colóquela contra la parte inferior de la unidad PITT Cooking. **¡ATENCIÓN AL POSICIONAMIENTO, VEA PASO 4!**

* Distancia mínima de 80 mm



4. Coloque la barra de soporte de forma que los tornillos de ajuste, la conexión de gas y el bloque eléctrico sean de libre acceso.

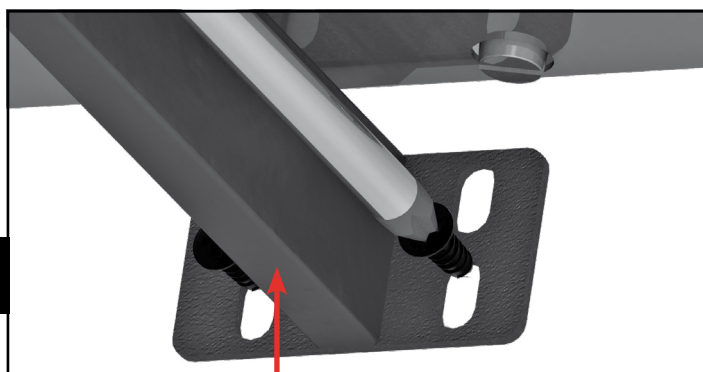

5. Empuje la barra de soporte firmemente contra la parte inferior de la unidad PITT Cooking y apriete a mano los dos tornillos inferiores. Repita este paso en el otro lado del armario.

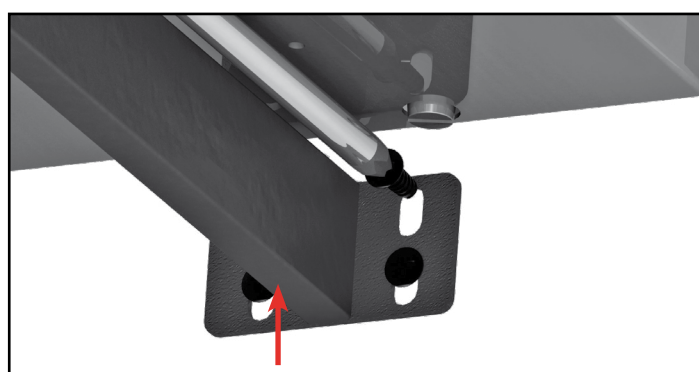

6. Empuje la barra de soporte firmemente contra la parte inferior de la unidad PITT Cooking y apriete completamente los dos tornillos superiores y luego los tornillos inferiores.

PITT

COOKING

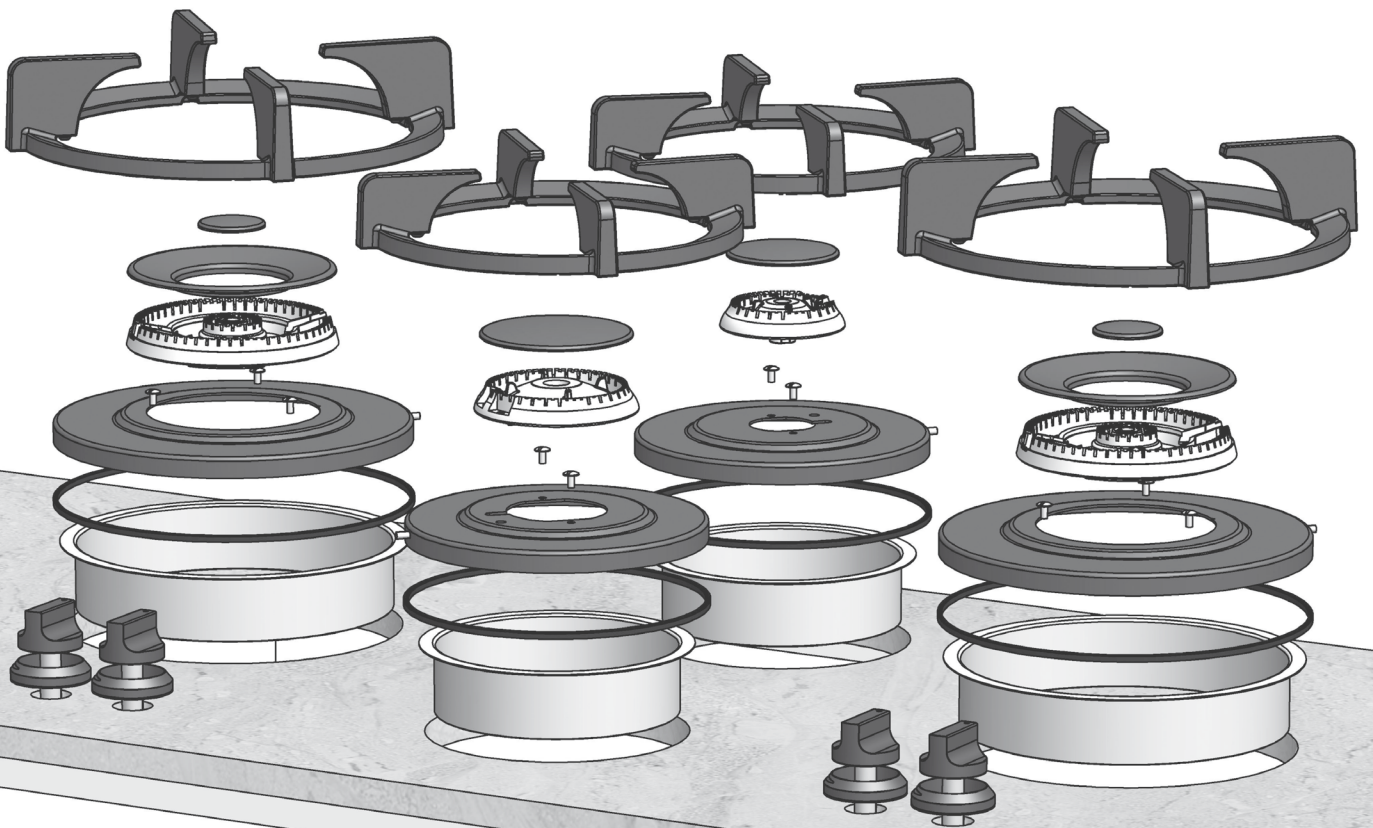

Gas
Top Side

IT *Manuale per l'utente*

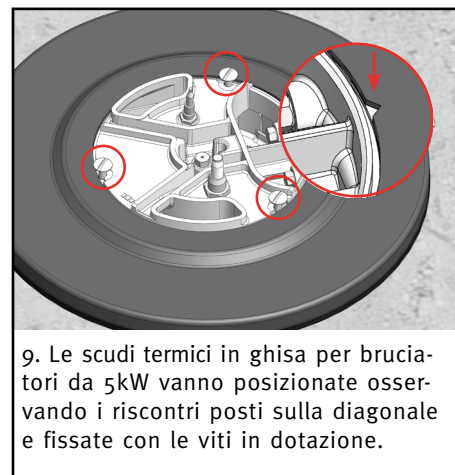
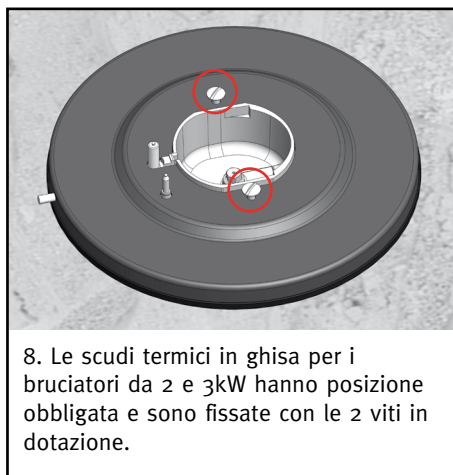
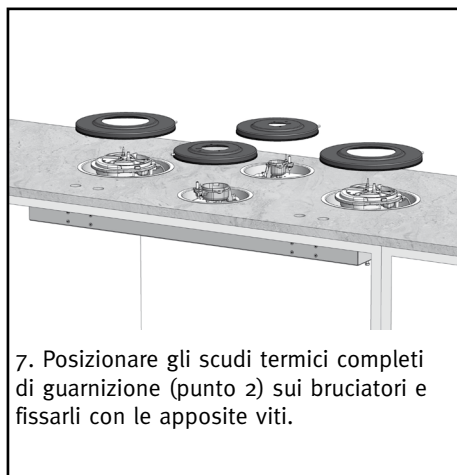
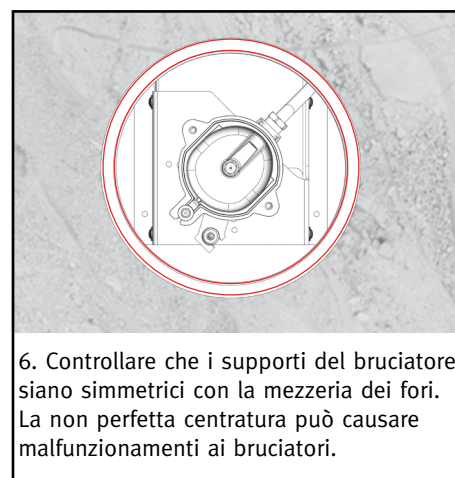
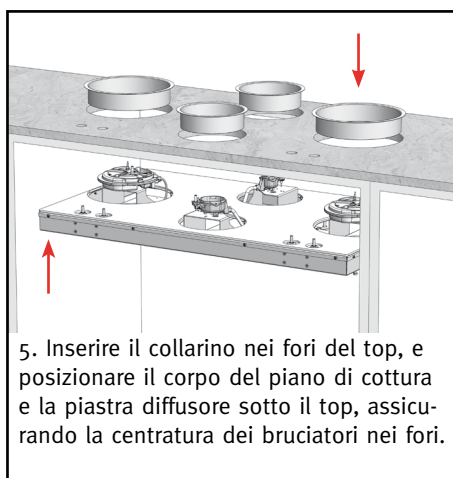
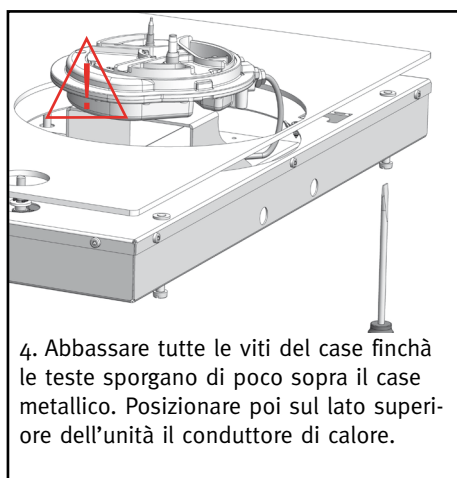
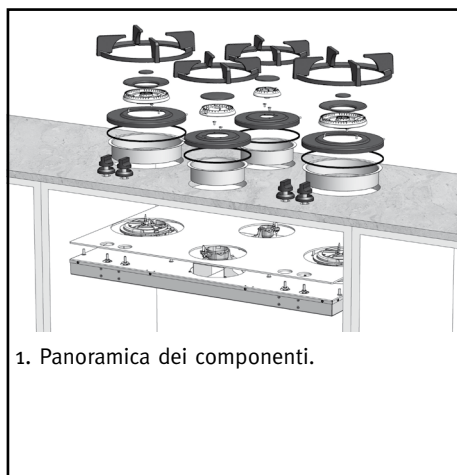

Importante!



Se le manopole **non** sono regolate correttamente, i bruciatori non si accendono oppure producono un fuoco disomogeneo.

Per la validità della **garanzia** e il **funzionamento corretto** del piano cottura, assicurarsi che il montaggio venga effettuato esattamente con descritto nel presente manuale. the letter.



10. Le manopole di comando sono composte da due parti: la manopola e la base adesiva da fissare al top, come ultima operazione d'installazione.



11. Far scorrere delicatamente l'unità in una posizione dove tutti i perni delle pastiglie dei gas sono al centro di i loro ritagli.



12. Inserire le manopole premendo verso il basso. Manopola e base devono combaciare, rilasciare e verificare che la manopola ritorni in alto.



13. Se le manopole sono ben posizionate si deve evidenziare uno spazio tra base e parte inferiore della manopola e parte superiore dell'alloggiamento.

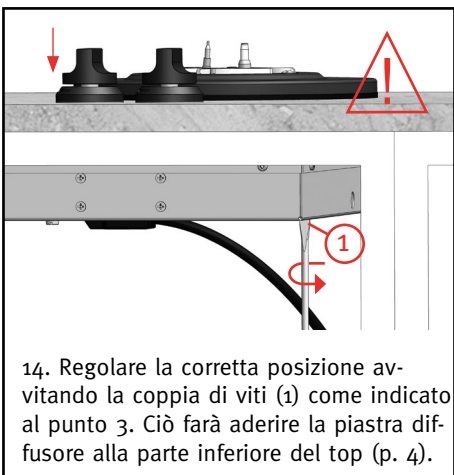

14. Regolare la corretta posizione avvitando la coppia di viti (1) come indicato al punto 3. Ciò farà aderire la piastra diffusore alla parte inferiore del top (p. 4).



15. A fine regolazione vi sarà una sporgenza della manopola dal filo sopra dell'alloggiamento.

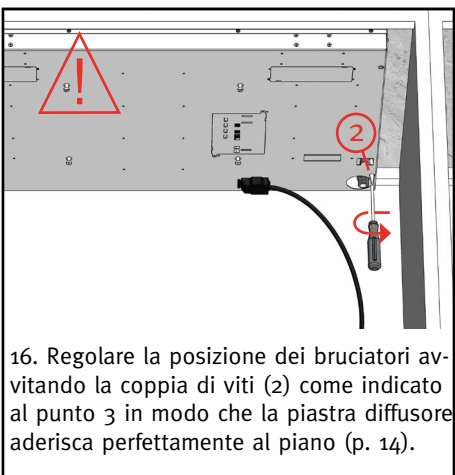

16. Regolare la posizione dei bruciatori avvitando la coppia di viti (2) come indicato al punto 3 in modo che la piastra diffusore aderisca perfettamente al piano (p. 14).

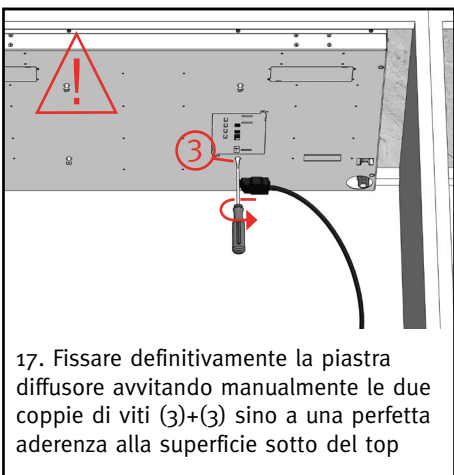

17. Fissare definitivamente la piastra diffusore avvitando manualmente le due coppie di viti (3)+(3) sino a una perfetta aderenza alla superficie sotto del top

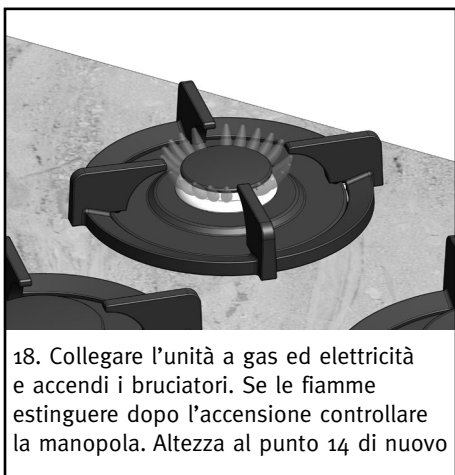

18. Collegare l'unità a gas ed elettricità e accendi i bruciatori. Se le fiamme estinguere dopo l'accensione controllare la manopola. Altezza al punto 14 di nuovo

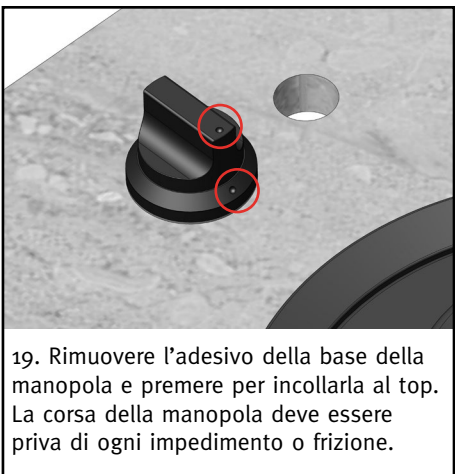

19. Rimuovere l'adesivo della base della manopola e premere per incollarla al top. La corsa della manopola deve essere priva di ogni impedimento o frizione.



20. Provare e riprovare più cicli di accensione e spegnimento per ciascun bruciatore posizionando la manopola sul massimo e sul minimo.

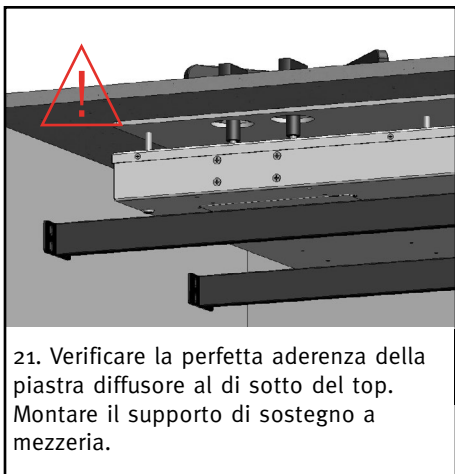

21. Verificare la perfetta aderenza della piastra diffusore al di sotto del top. Montare il supporto di sostegno a mezz'opera.

Istruzioni di montaggio set di supporto

Contenuto della confezione:

2x barre di supporto



4x inserti



16x viti con testa a croce 4,2x16 mm



Attrezzi necessari:

- Metro a nastro
- Cacciavite a croce
- Sega per metalli



1. Determina le dimensioni del mobile e taglia le barre di supporto. **ATTENZIONE: Lunghezza corretta della barra = Dimensioni all'interno del mobile - 4 mm.**

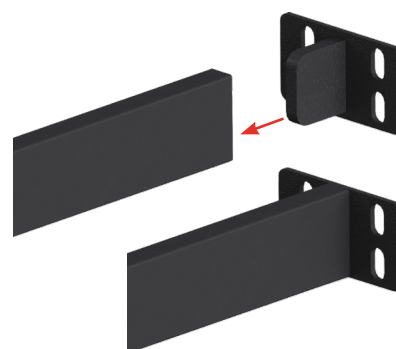

2. Posiziona gli inserti alle estremità delle barre di supporto tagliate su misura.

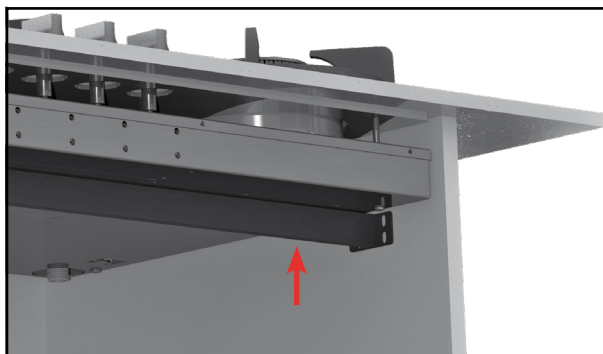

3. Inserisci la barra di supporto nel mobile e posizionala contro la parte inferiore dell'unità di cottura PITT Cooking. **ATTENZIONE AL POSIZIONAMENTO, VEDI PUNTO 4!**

* Distanza minima di 80 mm

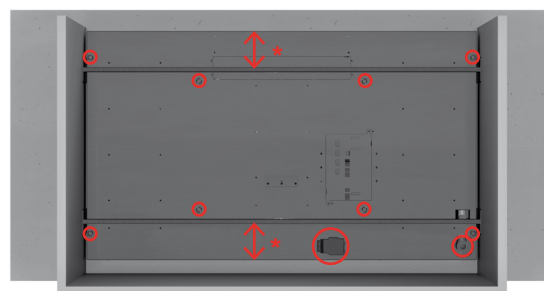

4. Posiziona la barra di supporto in modo che le viti di fissaggio, l'attacco del gas e il blocco elettrico siano facilmente accessibili.

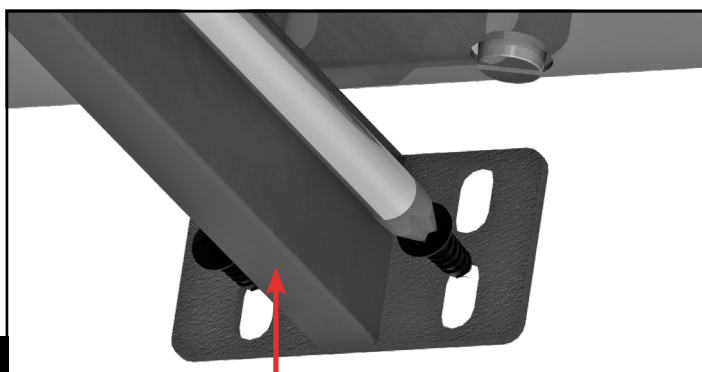

5. Spingi con forza la barra di supporto contro la parte inferiore dell'unità di cottura PITT Cooking e stringi a mano le due viti inferiori. Ripeti questo passaggio per l'altro lato del mobile.

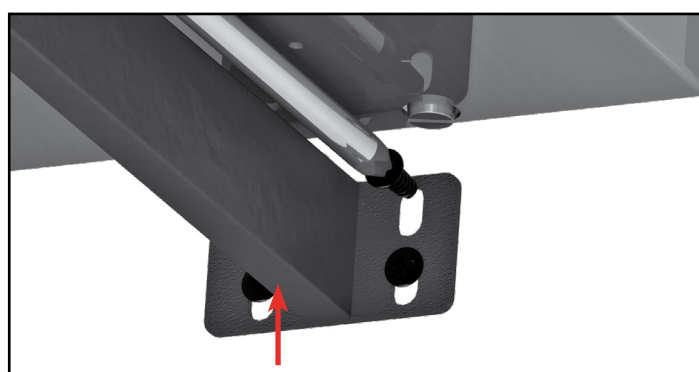

6. Spingi saldamente la barra di supporto contro la parte inferiore dell'unità di cottura PITT Cooking e stringi con forza prima le due viti superiori e poi quelle inferiori.



Made in Holland

PITT Cooking
Damzigt 54
3454 PS De Meern
The Netherlands

T: +31 (0)88 088 70 70
F: +31 (0)88 088 70 71
www.pittcooking.com