

*Made in Holland*

**PITT**  
COOKING



# ***Induction***

*Ebeko-I*  
*Top Side*

TS INDUCTIE 2025-9.1

**Exploded view**



- 1. **Sierring klein**  
GECOAT ALUMINIUM
- 2. **Sierring groot**  
GECOAT ALUMINIUM
- 3. **Inductiezone klein**  
GECOAT ALUMINIUM/ KERAMISCH GLAS

- 4. **Inductiezone groot**  
GECOAT ALUMINIUM/ KERAMISCH GLAS
- 5. **Bedieningsknop**  
ALUMINIUM/GLAS
- 6. **Cassette**  
ALUMINIUM

**Inductiezones**

**Kleine zone**

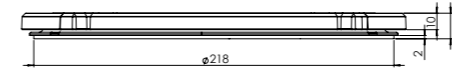
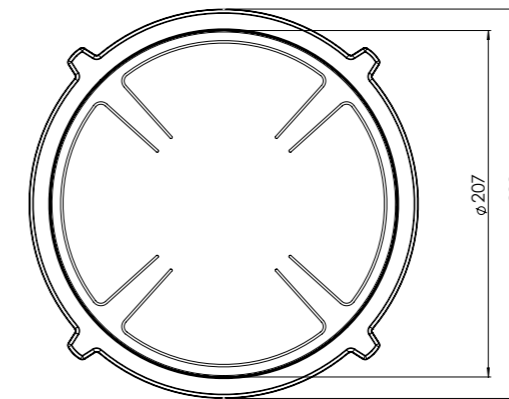

**KLEINE ZONE**

NOM. VERMOGEN  
**1400 Watt**

MAX. VERMOGEN  
**2100 Watt**

**Grote zone**

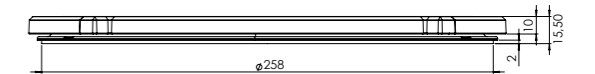
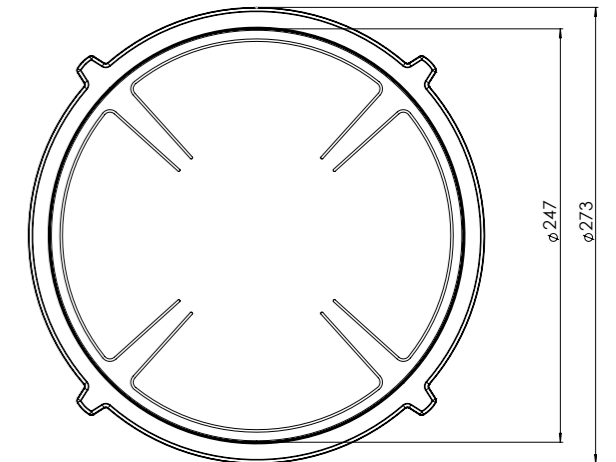

**GROTE ZONE**

NOM. VERMOGEN  
**2300 Watt**

MAX. VERMOGEN  
**3000 Watt**

## Bedieningsknop

### Maatvoering bedieningsknop

3D-afbeelding Top Side knop



3D-afbeelding Front Side knop



### Maatvoering bedieningsknop

Vooranzicht bedieningsknop

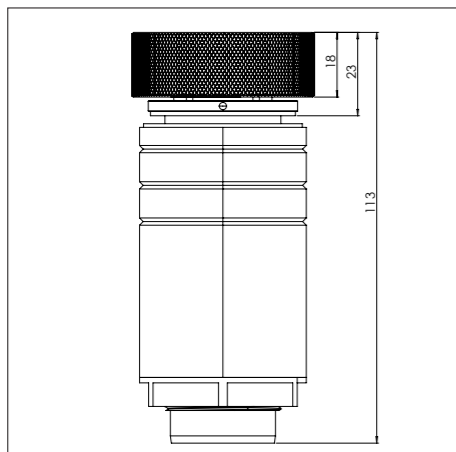

Bovenaanzicht bedieningsknop

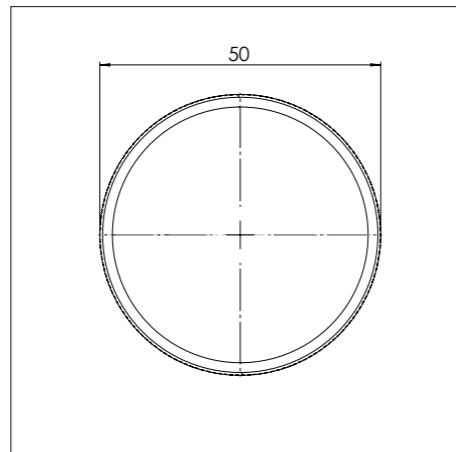

## Bedieningsknop

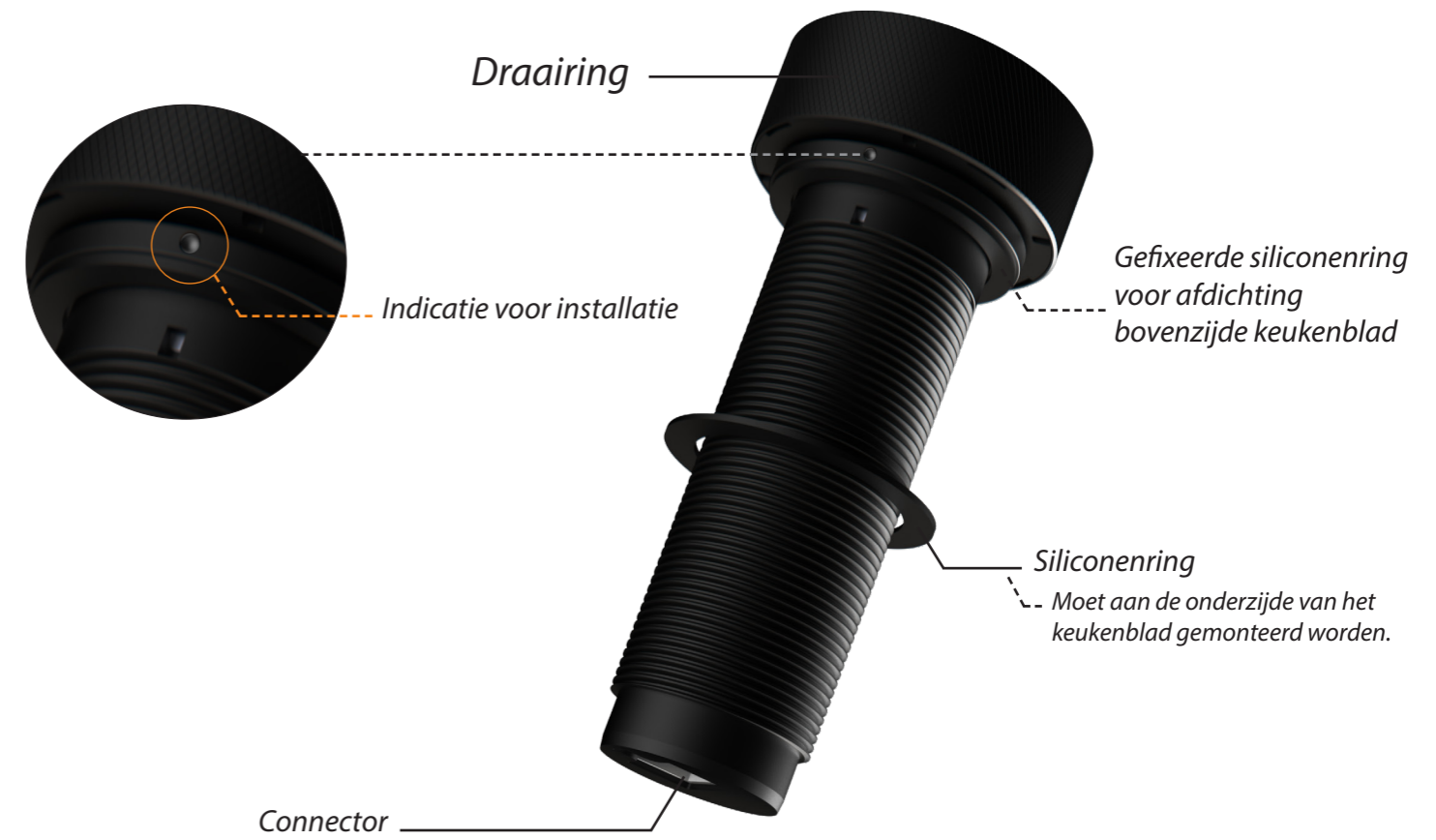

**Technische tekening**

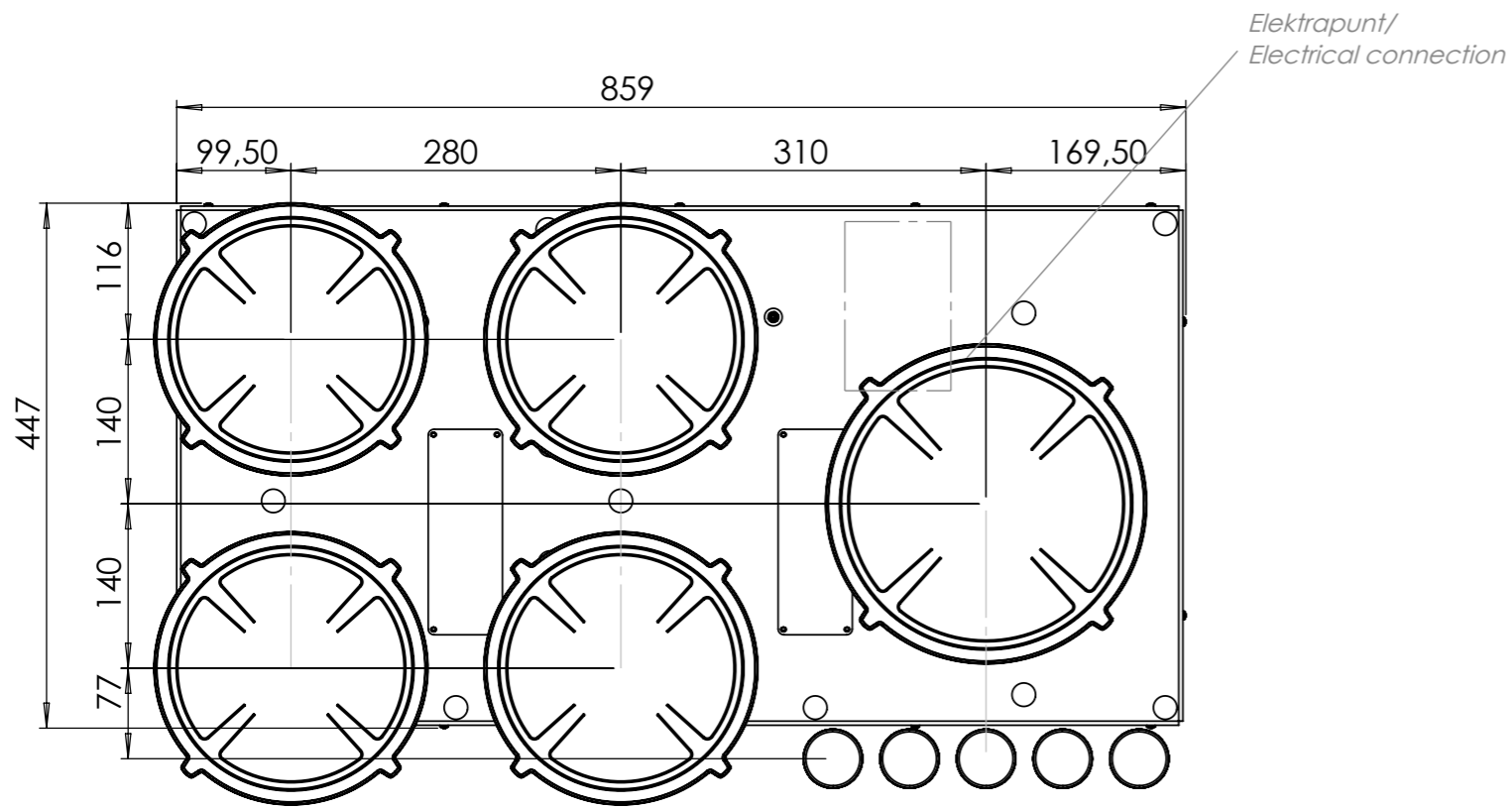

**Bovenaanzicht / Top view**

**Technische tekening**

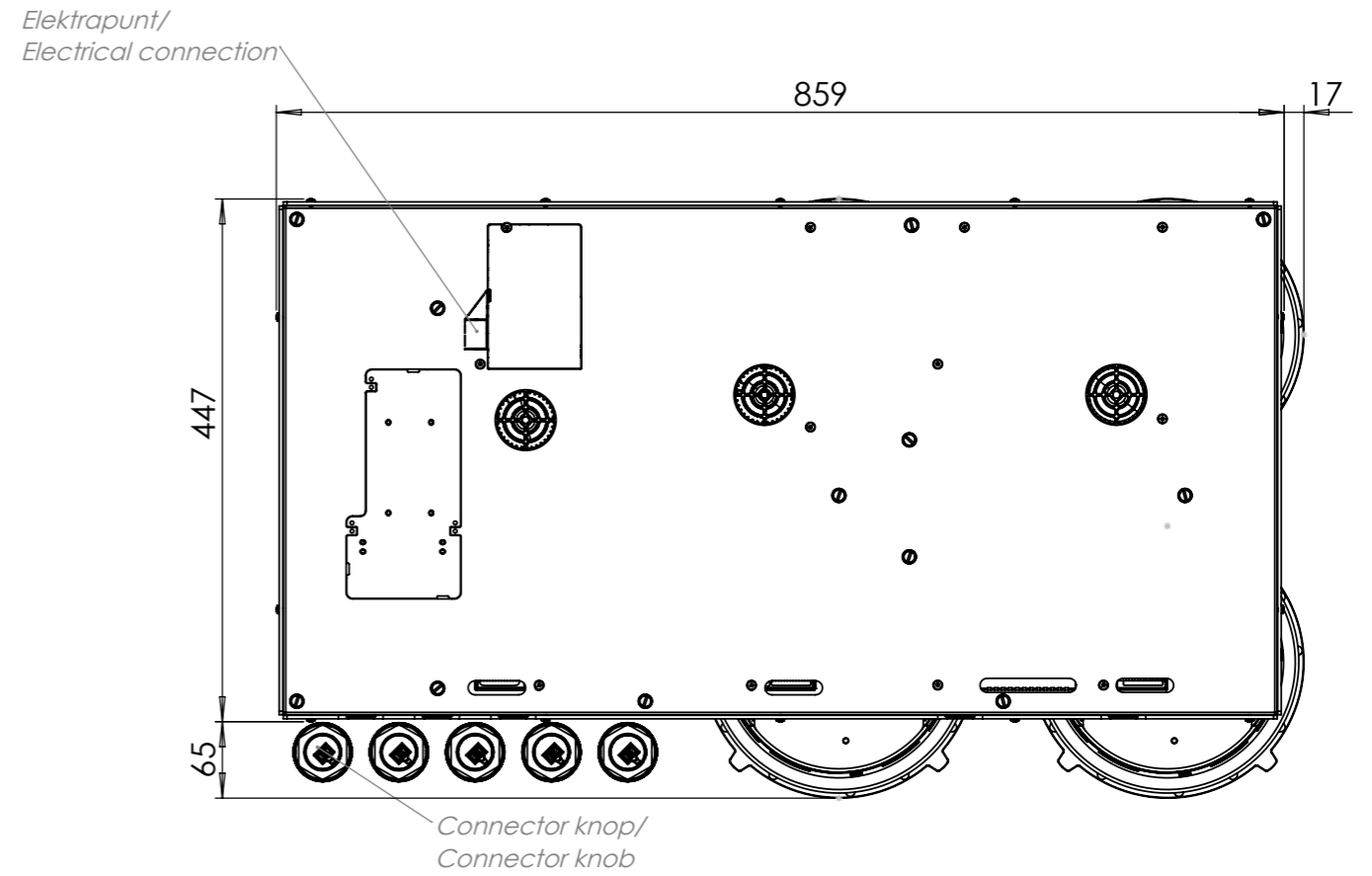

**Onderaanzicht / Bottom view**

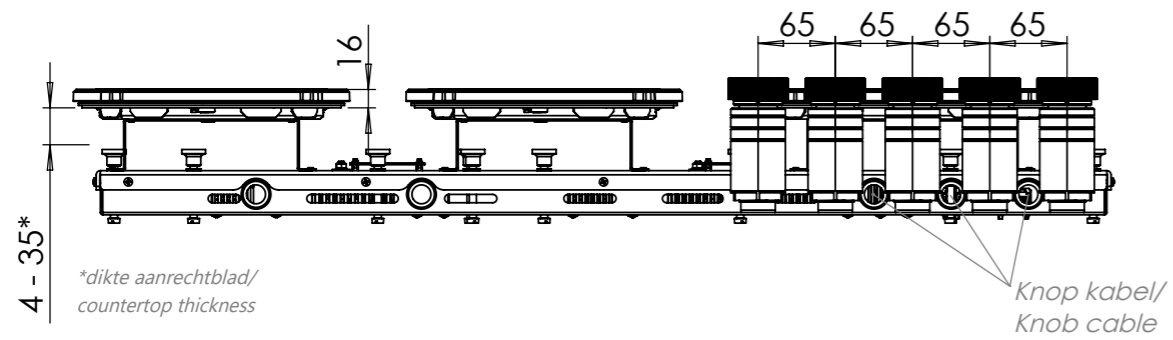

**Vooraanzicht / Front view**

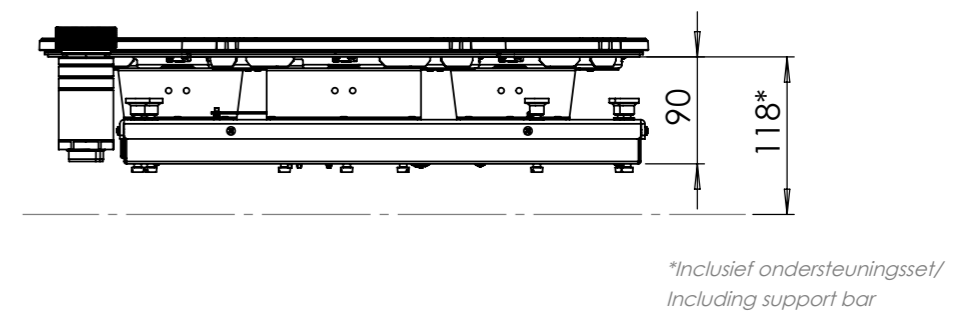

**Zijaanzicht / Side view**





Installatievoorschriften inductie



Installatiehandleiding inductie



Gebruikshandleiding inductie

*Made in Holland*

**PITT**  
COOKING



***Induction***

*Ebeko-I*

*Front Side*

**Exploded view**



- 1. **Sierring klein**  
GECOAT ALUMINIUM
- 2. **Sierring groot**  
GECOAT ALUMINIUM
- 3. **Inductiezone klein**  
GECOAT ALUMINIUM/ KERAMISCH GLAS

- 4. **Inductiezone groot**  
GECOAT ALUMINIUM/ KERAMISCH GLAS
- 5. **Bedieningsknop**  
ALUMINIUM/GLAS
- 6. **Cassette**  
ALUMINIUM

**Inductiezones**

**Kleine zone**

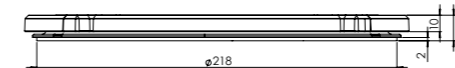
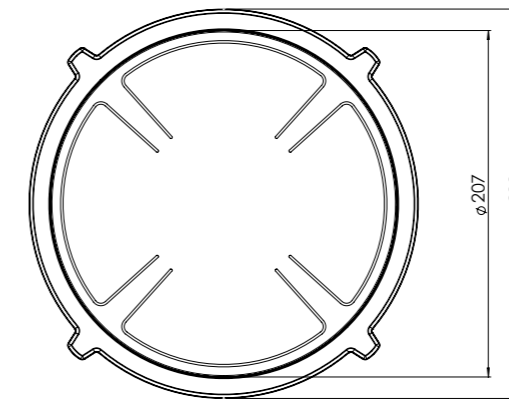

**KLEINE ZONE**

NOM. VERMOGEN  
**1400 Watt**

MAX. VERMOGEN  
**2100 Watt**

**Grote zone**

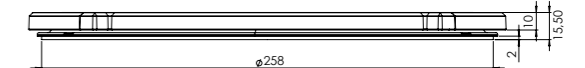
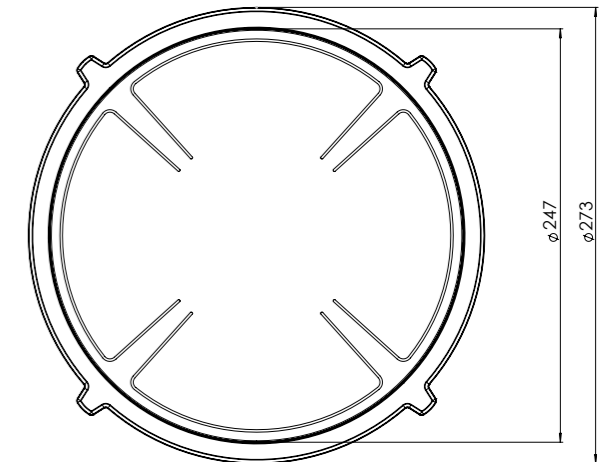

**GROTE ZONE**

NOM. VERMOGEN  
**2300 Watt**

MAX. VERMOGEN  
**3000 Watt**

## Bedieningsknop

### Maatvoering bedieningsknop

3D-afbeelding Top Side knop



3D-afbeelding Front Side knop



### Maatvoering bedieningsknop

Vooranzicht bedieningsknop

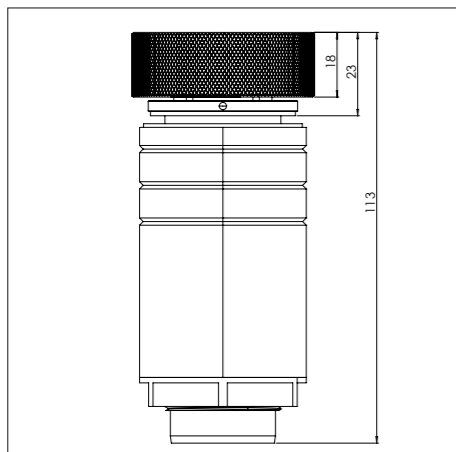

Bovenaanzicht bedieningsknop

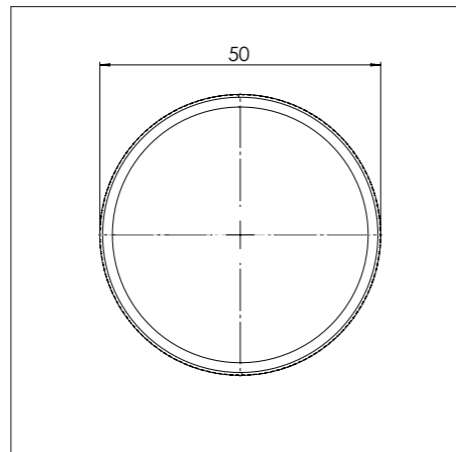

## Bedieningsknop

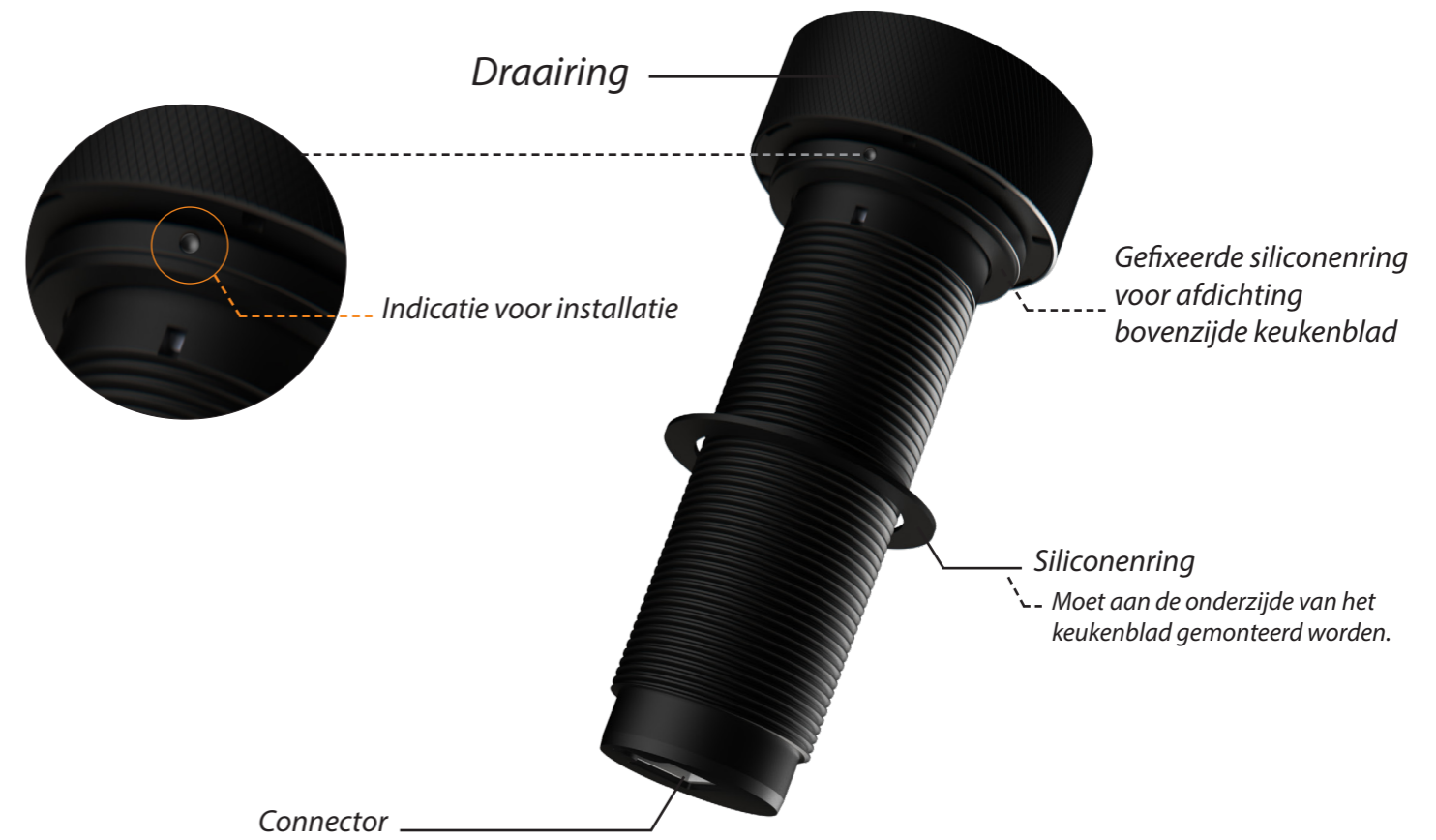

**Technische tekening**

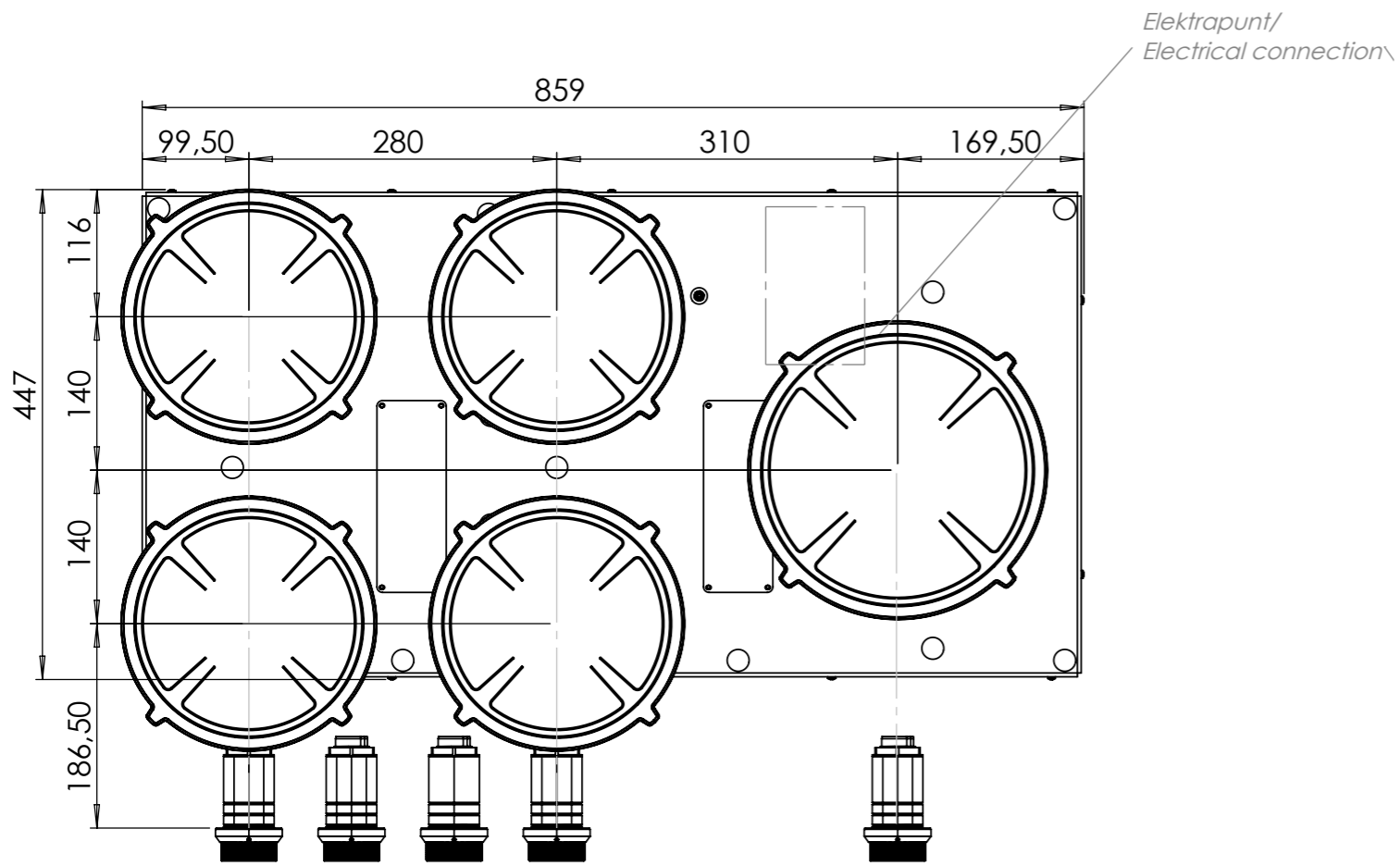

**Bovenaanzicht / Top view**

**Technische tekening**

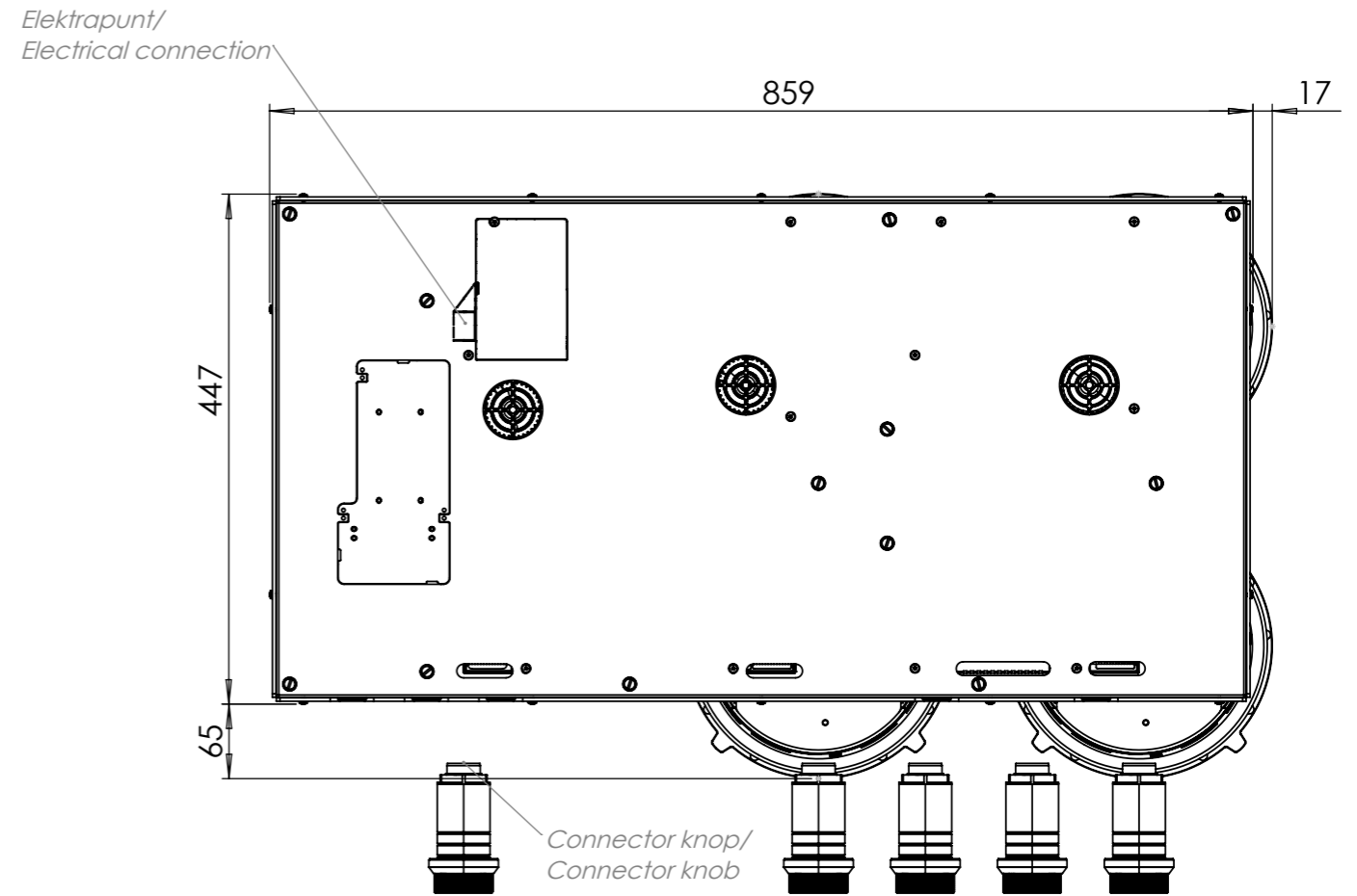

**Onderaanzicht / Bottom view**

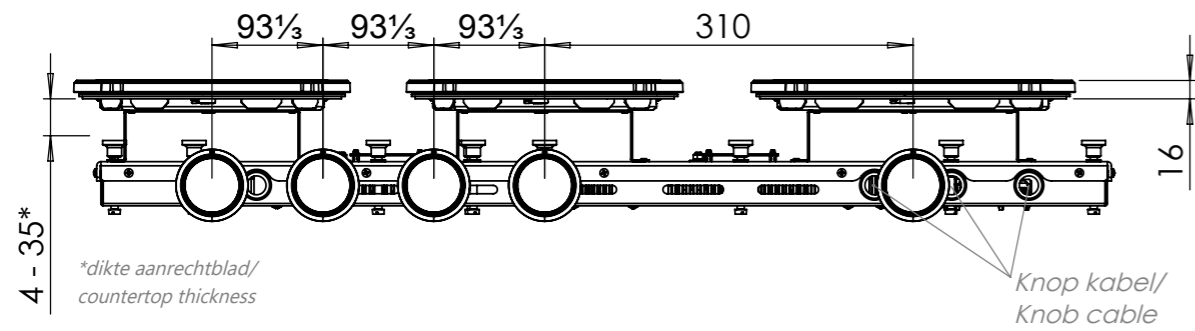

**Vooraanzicht / Front view**

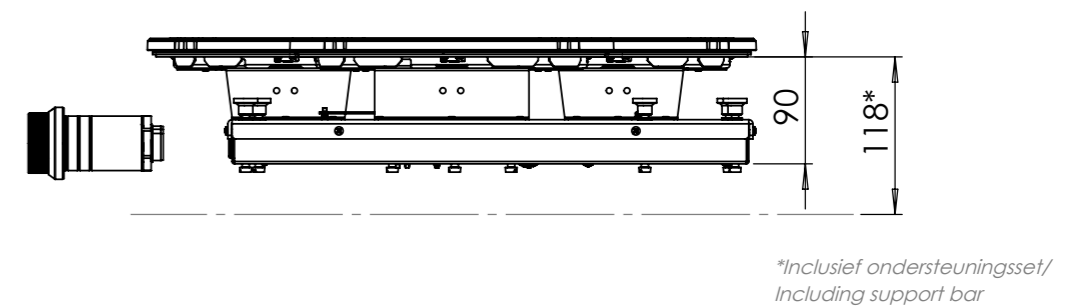

**Zijaanzicht / Side view**

## Gatenpatroon

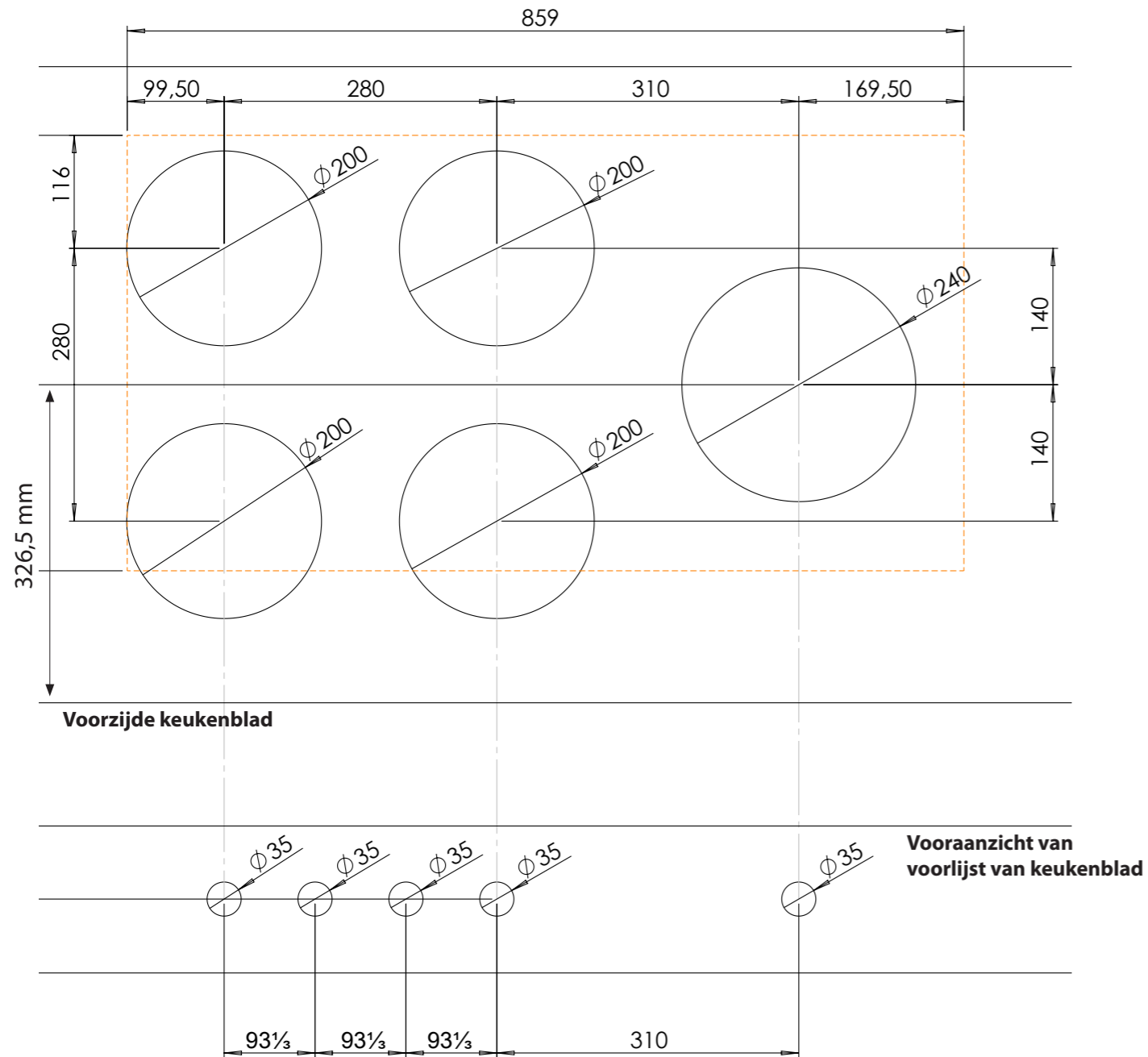

Gatenpatroon  
DXF bestand

## Technische gegevens

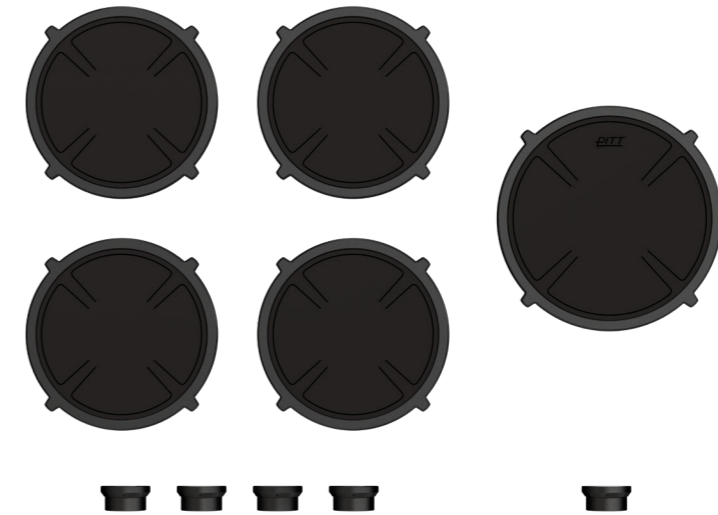

Model	Ebeko Front Side
Type zones	4x zone klein, 1x zone groot
Uitvoering	Black (volledig zwart)
Automatische panherkenning	✓
Vermogensniveaus	0 - 10 + Boost
Nominale spanning	380-415 V, 3N~
Maximaal vermogen	10360 W
Netto gewicht	18 kg

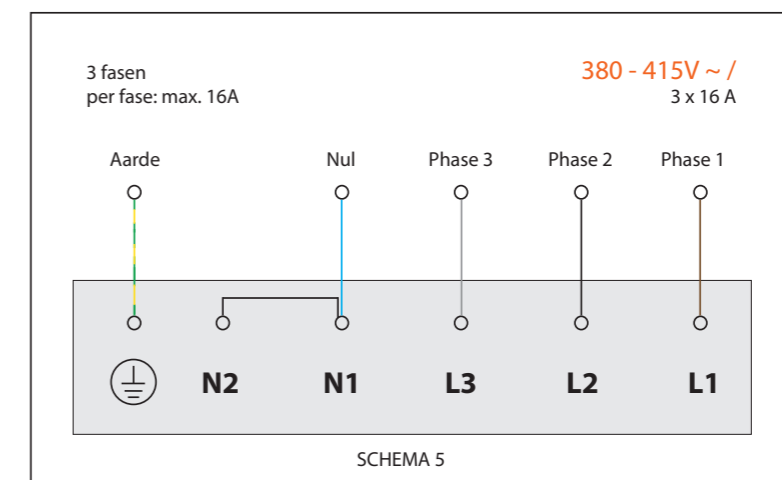



Installatievoorschriften inductie



Installatiehandleiding inductie



Gebruikshandleiding inductie